

TOSUN



In-vehicle network toolchain provider
LIN / CAN / CAN FD / FlexRay / Ethernet

TSMMASTER

Engineer Everything !

Shanghai TOSUN Technology Ltd.

Contents

Software

- 03 TSMaster
- 04 Ethernet
- 08 Simulation
- 13 Scripting
- 15 Analysis
- 17 Test System
- 20 Diagnostic
- 23 Calibration
- 24 Engineering
- 25 Additional Features

Hardware

- 31 CAN/CAN FD/LIN
- 35 FlexRay
- 36 Ethernet
- 37 SENT/PSI5
- 37 Datalogger
- 38 CAN/CAN FD to Fiber Optic
- 38 CAN Trigger
- 39 GPS to CAN FD/CAN device
- 39 High-Precision Time Sync device
- 38 Offline Gateway
- 40 CAN/CAN FD Disturbance device
- 41 Handheld UDS Flashing device
- 41 TIO Test Module
- 42 TTS Test System
- 43 Real Time Simulation Test System

Solution

- 43 ECU Diagnostics and Flashing
- 44 Bus Conformance Test
- 45 HIL Simulation
- 45 SecOC Test
- 46 Charging Test
- 47 EMB Calibration/Test
- 47 Motor Test
- 48 Component Durability Test
- 49 FCT Testing
- 49 EOL End of Line Test
- 50 Tablet Solution Based
- 52 TPAD Series Ordering
- 53 OTA HIL Test
- 54 In-Vehicle Data Acquisition
- 55 Cloud Platform
- 56 Accessories

About TOSUN

TOSUN Technology was founded by a team of experts with over a decade of experiences in the automotive industry. With deep expertise in automotive electronics and system integration, we are committed to delivering innovative, reliable, and cost-effective solutions that help engineers streamline their workflows and enhance productivity.

Our goal is to empower engineers worldwide by providing a powerful and intuitive toolchain that meets the evolving demands of modern automotive technology. Through continuous research and development, we strive to set new industry standards and drive technological advancements in the field.



A comprehensive tool for automotive electronics simulation and testing

TSMaster is a powerful virtual instrument software platform that connects and controls all TOSUN hardware to enable automotive bus embedded code generation, monitoring, simulation, development, diagnosis, calibration, bootloader, I/O control, test and measurement, EOL, and other functions.

TSMaster supports ECU algorithm simulation testing (soft real-time HIL) for Matlab Simulink joint simulation and CarSim dynamic models.

- Provides a range of convenient features and editors to execute ECU code directly in TSMaster, and supports C script and Python script editing
- Support mini program function to customize simulation test panels, test processes, test logic and even the entire test system, and automatically generate reports. Code is hardware-agnostic, easy to share, reference, and apply across different hardware platforms

TSMaster has a wide range of compatibility and can be perfectly integrated with test systems to achieve multi-hardware, multi-channel joint simulation and testing, which can meet the needs of PV/DV testing and verification of various automotive electronic components and assemblies, as well as off-line inspection.

- Compatible with Vector, Kvaser, PEAK, IXXAT, ICS and other bus tools
- Compatible with mainstream instruments (such as oscilloscopes, waveform generators, digital multimeters, etc.) and boards (such as AI, DI, DO, etc.)

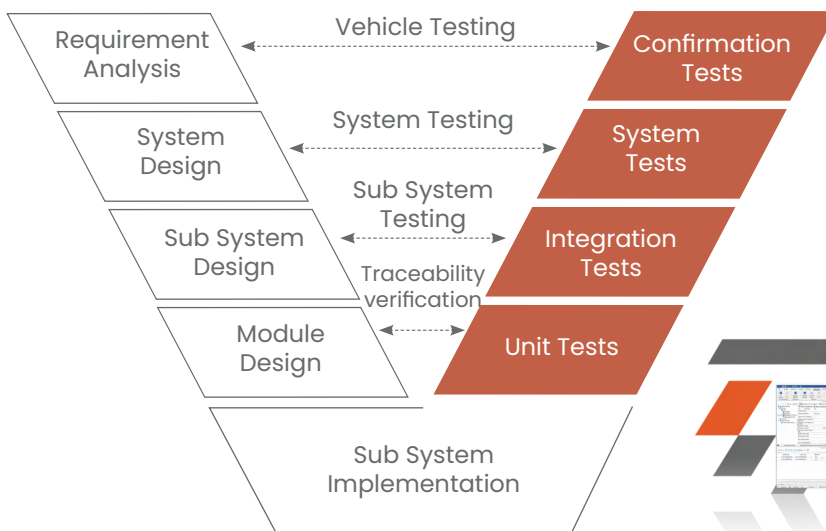

Free Trial for TSMaster
30 days!

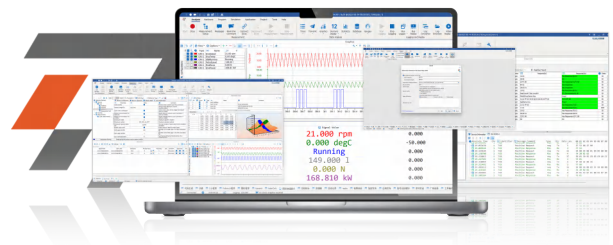

Ethernet

TSSocket & TSSocket API

The TSSocket protocol stack is developed by TOSUN and is independent of the TCP/IP stack provided by the operating system. It offers the following features.

- Each individual hardware interface can be configured with a separate TCP/IP protocol stack
- It does not automatically send Ethernet frames related to the Windows/Linux operating systems
- It allows greater flexibility in configuring MAC and IP addresses. Multiple MAC addresses (virtual NICs) can be assigned to a single hardware interface, and each NIC can have multiple IP addresses/VLANs
- Based on TSSocket, any MAC device can be simulated freely. Each MAC device can have different IP addresses, and each IP address can have multiple ports

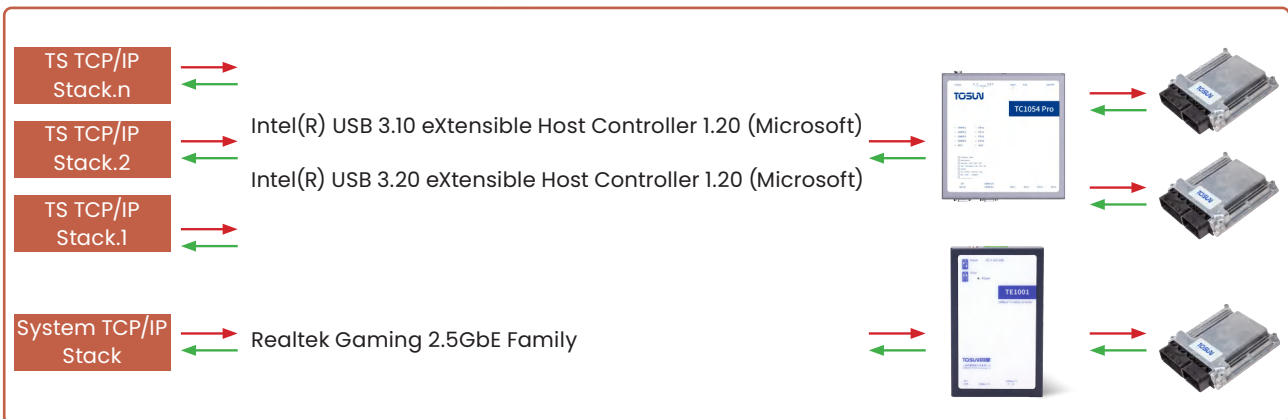
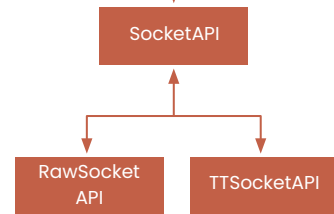
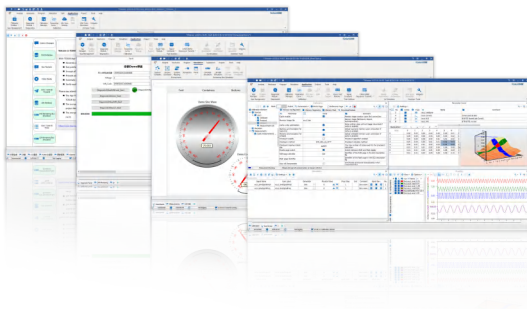
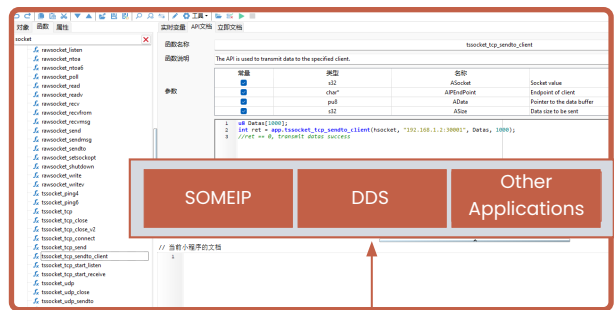
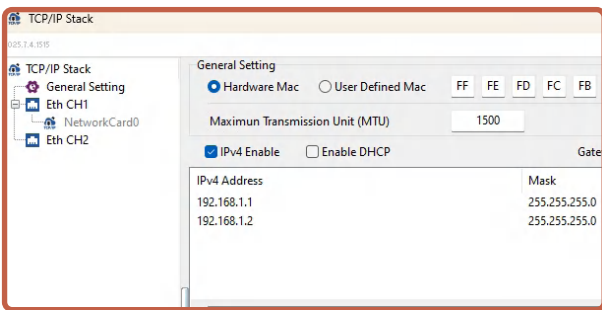

The TSSocket protocol stack provides a secondary development API (TSSocket API), which is compatible with TOSUN Ethernet hardware and supports upper-layer applications such as SOME/IP, DDS, and other Ethernet protocols.

- Rawsocket interface: Complies with the socket interface definitions provided by Linux. Suitable for developers familiar with network programming and can be integrated into existing application-layer code
- Tsocket interface: Designed for simple TCP/UDP transmission and reception. The API handles blocking and thread termination internally, so developers do not need to manage threads manually. It is ideal for developers new to socket programming

```
void on_start_NewOn_Start1(void) { try { // 程序启动事件
1  #define NETWORK1 0)
2  int hsocket = 0;
3  if(0 == com.tsocket_tcp(
4  NETWORK1,
5  "192.168.1.1:20001",
6  &serverSocket
7  )){
8  app.log_text("Create tcp socket1 success", lv10K);
9  log("serverSocket: %d", serverSocket);
10 if(0 == com.tsocket_tcp(
11 NETWORK1,
12 "192.168.1.2:30001",
13 &clientSocket
14 )){
15 app.log_text("Create tcp socket2 success", lv10K);
16 log("clientSocket: %d", clientSocket);
17 if(0 == com.tsocket_tcp_start_listen(serverSocket)){
18 app.log_text("serverSocket start listen success", lv10K);
19 if(0 == com.tsocket_tcp_connect(clientSocket, "192.168.1.1:20001")){
20 app.log_text("connect to server success", lv10K);
21 com.tsocket_tcp_start_receive(serverSocket);
22 com.tsocket_tcp_start_receive(clientSocket);
23 }
```

Ethernet Frame Logging and Playback

TSMaster supports the parsing of basic Ethernet protocols. For SOME/IP and similar application-layer protocols, a database must be imported before parsing can be triggered. Once the database is imported, both simulation and offline playback can directly display the parsed results of the protocols and signals.

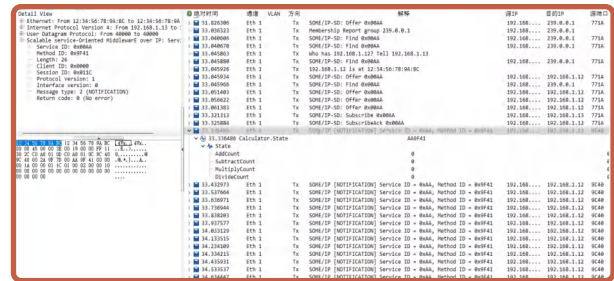

Ethernet Frame Filtering

TSMaster supports filtering of frame information based on Ethernet fields.

Filtering rules allow for operations such as greater than/less than comparisons, as well as logical operations like AND, OR, and NOT. In the example shown in the image, the filter string "someip && !someipsd" is used to display frames that are based on the SOME/IP protocol but exclude those of the SOME/IP-SD protocol.

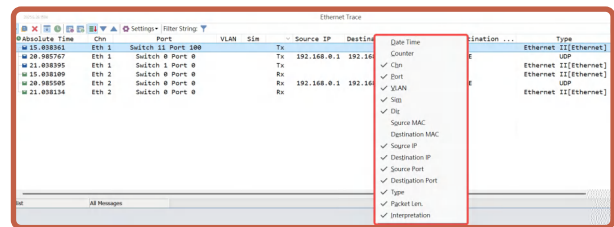

Ethernet Simulation

The Ethernet communication simulation module can simulate the process of real ECUs sending and receiving communication frames, enabling verification of the software's accuracy and stability when handling different types of frames.

This module can flexibly simulate various communication fault scenarios, such as network RBS latency, packet loss, and injection of erroneous frames. It supports robustness testing and helps developers assess the software's performance under complex communication conditions.

Once the Ethernet communication simulation is started, the parsed AUTOSAR PDUs can be viewed under [Analysis] -> [Ethernet Frame Information].

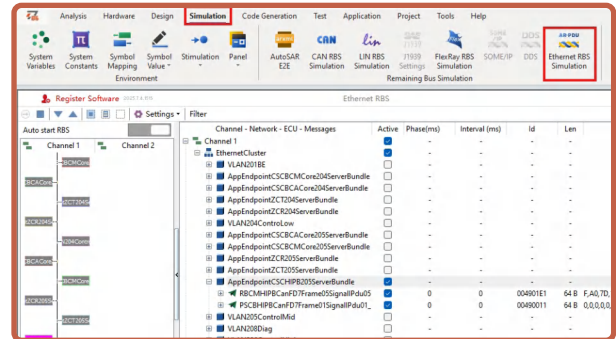
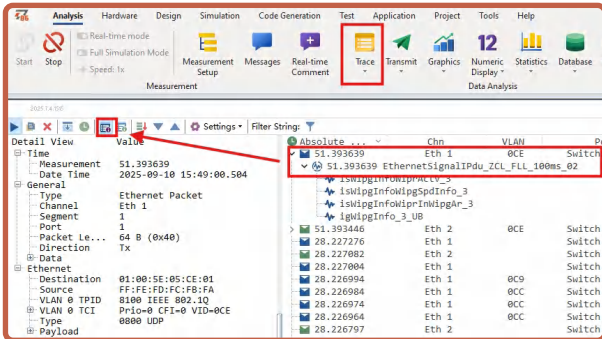

SOME/IP Basic Features:

- Supports importing AUTOSAR ARXML files
- Enables serialization/deserialization based on ARXML information
- Supports automatic generation of simulation participants and multi-participant simulation
- Supports automatic generation of data types and symbolic variables from the database
- Supports scripting/programming interfaces
- Supports manual modification of IP and port information in ARXML

Key Features:

- The simulation mode supports simultaneous generation of counterpart participants for rapid simulation
- Supports modification of basic information (such as IP/MAC) for simulation, avoiding the inconvenience of editing the ARXML file
- Seamlessly integrated with panel/image modules, allowing quick access to serialization results using user variables

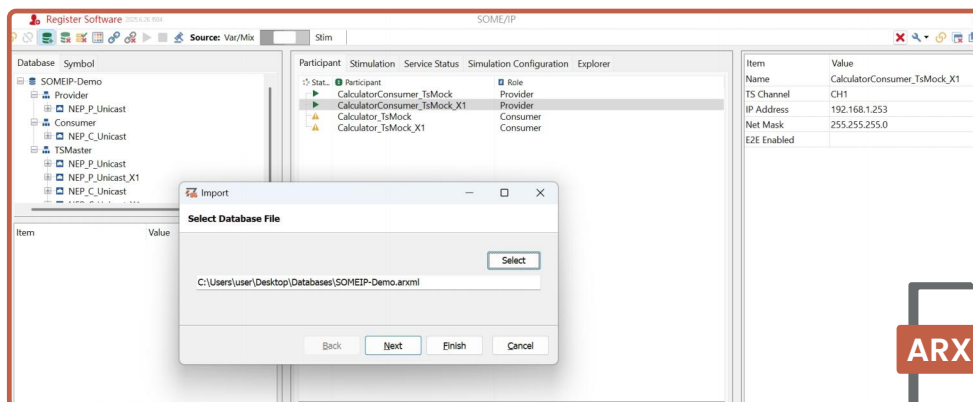

The serialized results of Ethernet-SOME/IP generated by TSMaster can be directly applied in the Trace interface, supporting the import of recording files such as BLF, PCAP, and PCAPNG for online playback and offline simulation.

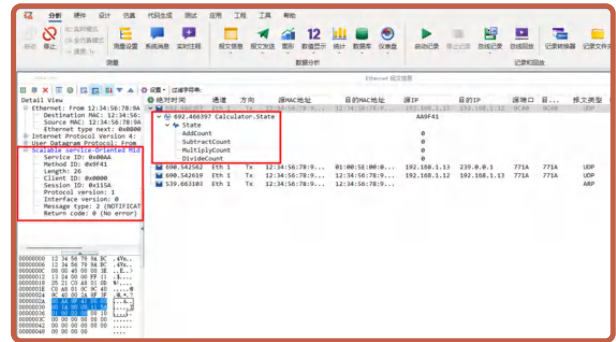
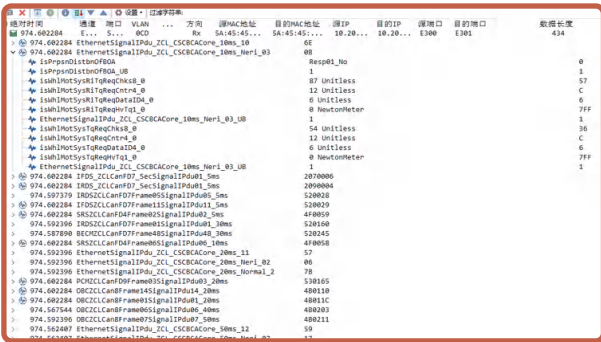

SOME/IP: File Import and Information Generation Functionality

- Supports ARXML files from AUTOSAR CP/AP
- Generates type data from ARXML for user programming in C micro-applications
- Generates serialization information from ARXML to enable data serialization/deserialization
- Automatically generates simulation code for participants in the file, which can be executed directly
- Automatically generates simulation code for the counterpart of the participant, facilitating quick environment setup and testing

SOME/IP: Simulation Functionality

- The simulation mode supports simultaneous generation of counterpart participants, enabling rapid simulation and testing
- Allows modification of basic information (e.g., IP/MAC address) for simulation purposes, avoiding the inconvenience of altering the ARXML file
- Simulation code (C/C++) for participants and their counterparts defined in the ARXML can be executed directly, enabling users to implement custom business logic based on the generated code

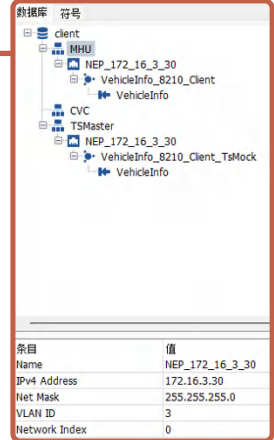
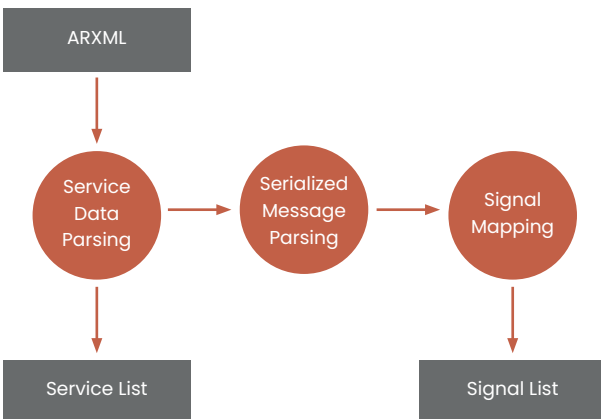
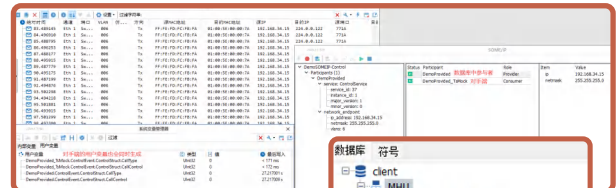

SOME/IP DEMO

Integration with Other Modules

- Enables modification of service-type data via signal value modules and similar components
- Provides panel-based management of service variables to facilitate efficient data interaction and user input
- Supports integration with graphical applications and related tools to implement comprehensive testing functionalities

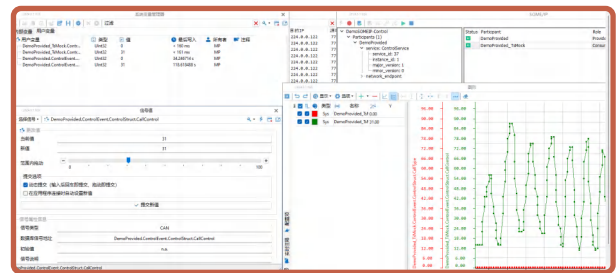

Simulation

System Variables

To facilitate data interaction both within and outside the software, TSMaster provides a system variable mechanism. Based on their generation principle, system variables are mainly divided into two types: Internal Variables and User Variables.

The key differences are as follows:

- Internal Variables are automatically created and released by the system. Users cannot manually add or delete them
- User Variables are created and managed by users themselves
- The architecture of the system variable mechanism is illustrated below:

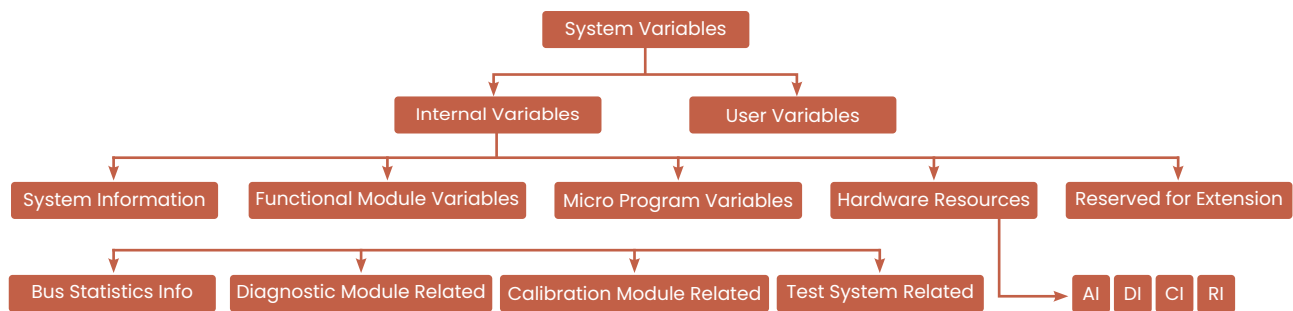

In addition to common data types such as int and string, this mechanism also digitizes internal hardware and software module resources. For example, in the case of digital input (DI) interfaces, if the connected hardware device includes two physical DI ports, the software will automatically generate two corresponding DI system variables internally, as shown in the following figure:

Internal Variables	User Variables	Type	Value	Last Wri...	Owner	Comment
Internal Variable		Int32	0	n.a.	TTS	Digital Input/Output Channel
Digital.DI01						
Digital.DI00		Int32	0	n.a.	TTS	Digital Input/Output Channel

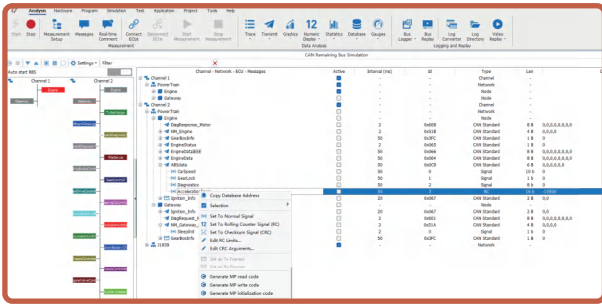

In TSMaster, developers can not only manually define verification algorithms via C/Python scripts, but also configure CRC check signals and RollingCounter signals directly through the RBS panel. Furthermore, E2E signals can be automatically extracted from DBC/ARXML/Fibex files, with corresponding scheduling logic generated automatically. This greatly reduces the workload of simulation script development.

CAN Bus Simulation

- The CAN RBS module can simulate multiple virtual ECU nodes, including their associated channels, networks, nodes, messages, and signal attributes
- The CAN RSB module supports CRC, Rolling Counter, and E2E (End-to-End) validation mechanisms
- Built-in E2E algorithms can automatically extract E2E information directly from DBC, ARXML, or FIBEX files, significantly reducing development time and complexity

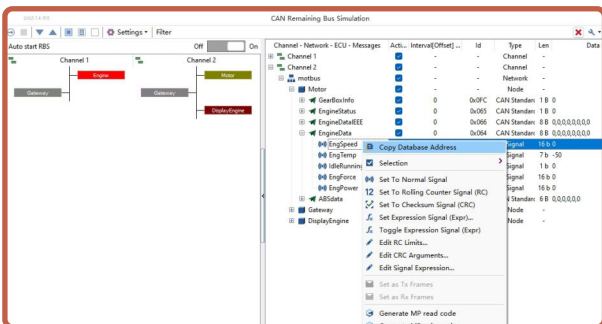
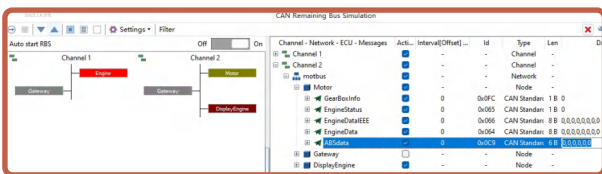

Graphical Panel

TSMaster's Panel function allows users to design independent software interfaces. It acts as an integrated development environment (IDE), enabling users to build customized user interfaces that function as standalone applications.

Although these applications rely on the TSMaster core engine, they can operate independently and are virtually indistinguishable from traditional applications developed through standard IDEs.

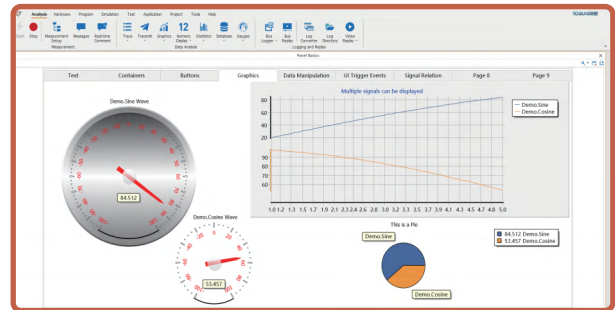

Within the panel, users can bind bus signals for graphical display. When combined with residual bus simulation (RBS), it also enables control over signal and message transmission. Together with system variables, more advanced automation features can be implemented.

- A rich set of UI components, including various gauges, buttons, indicators, progress bars, and input/output fields
- Support for associating C scripts with the panel to implement testing logic
- Integration with system variables to link diagnostics and calibration, enabling fast customization of diagnostic/calibration panels

AutoSAR E2E

The AutoSAR E2E simulation module in TSMaster enables the transmission of AutoSAR E2E messages, as well as the detection and validation of received E2E information. The user interface clearly displays whether the transmitted and received E2E data are correct.

Key features include:

- E2E message transmission
- E2E message checking
- E2E fault injection

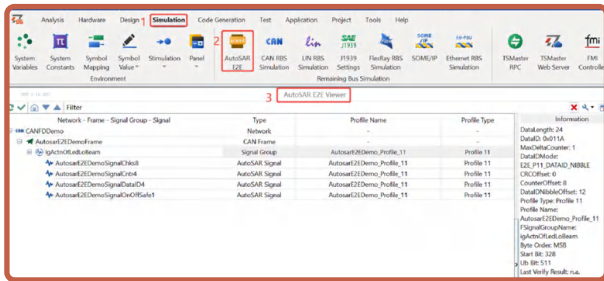

Co-Simulation – TSRPC

TSMaster RPC is a protocol for simple, fast, and real-time data exchange between TSMaster and other systems via Ethernet connection. This protocol allows other systems to read and write access TSMaster system variables and bus messages. Typically, these other systems are HIL simulation software such as Simulink, Carmaker, etc.

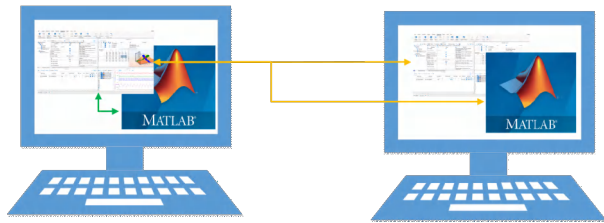

The protocol is based on TCP/IP and supports UDP IPv4. After importing an XML file containing data information, corresponding UDP packets can be sent according to protocol rules to achieve direct data exchange between TSMaster and other systems.

This protocol not only supports one-to-one communication between client and server but also supports complex communication topologies such as one-to-many, many-to-one, and many-to-many.

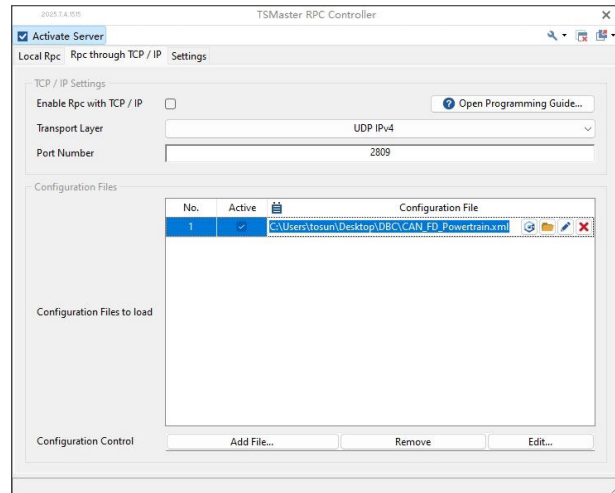

(Application Testing)

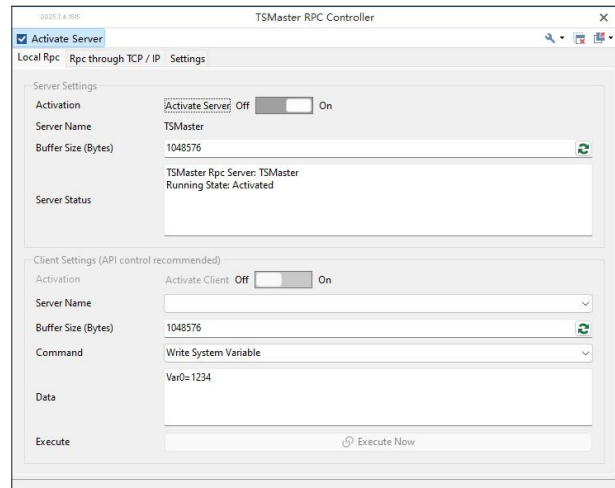

In HIL testing systems, higher real-time performance is required for data exchange. Therefore, we have defined a method for fast data communication, allowing users to directly add configuration XML files within the interface. It should be noted that UDP communication between different computers is carried out through their network interfaces.

Co-Simulation – RPC IP Editor

The TSMaster RPC IP Editor is a tool used to create and import XML files for the TSMaster RPC protocol. It allows users to edit and save XML files, and also supports importing FDX XML description files from CANoe.

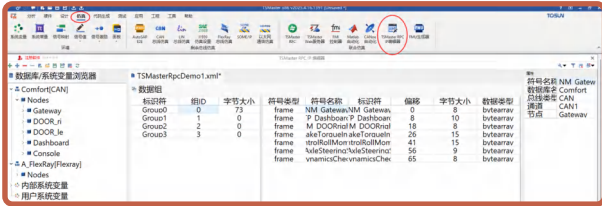

Co-Simulation – FMI/FMU

FMI is a commonly used standard interface in the field of automotive design and simulation. In general, FMI is software-independent, and the models used can originate from different tools or software. Models encapsulated based on the FMI interface protocol are called FMUs.

With the capability of TSRPC, FMU packages can be exported for co-simulation. TSMaster’s FMI controller supports loading FMUs of versions 2.0 and 3.0, enabling co-simulation between MATLAB and TSMaster.

TSMaster can import FMUs generated by other software, and it also supports exporting FMU files, facilitating integration with other systems. Since FMI primarily handles signal interactions for model import and co-simulation, it is necessary to import a database or create user-defined variables.

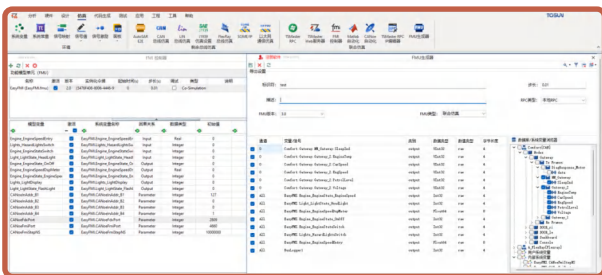

Web Server

The TSMaster Web Server module allows users to interact with TSMaster through a web browser.

Users can create panels within the TSMaster software and define all business logic, then publish them as a TSMaster Web interface. Once published, users can remotely log in to the Web Server to program and control TSMaster using the published panels, or use other programming methods to control TSMaster.

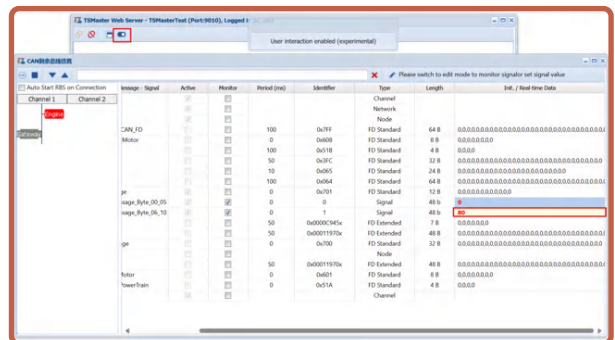
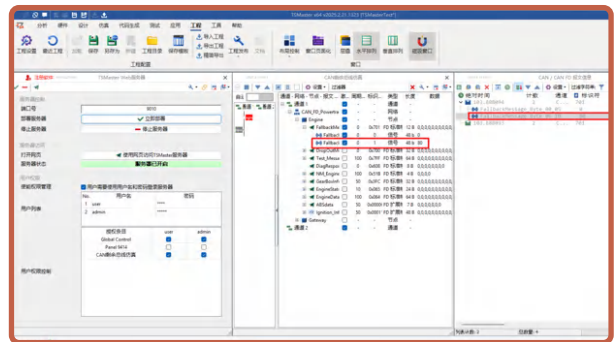

Example: Simulation signals can be configured via the web interface, and the updated message data can be viewed on the TSMaster server.

This module also enables features such as remote calibration, remote diagnostics, and remote panel control.

Mini-Program Library

Based on TSMaster's mini-program architecture, users can integrate the functionalities of their own mini-programs into the TSMaster software platform, providing API support for other user mini-programs. Mini-programs merged into the TSMaster software platform become part of the mini-program library. Through this library, users can continuously iterate and expand their self-developed software modules.

Since extensions can be built on existing TSMaster mini-programs, the development threshold is lowered. Secondary development enables rapid construction of new features or optimization of existing ones, facilitating quick iteration and timely response to market demands. These secondarily developed mini-programs have access to both the TSMaster platform APIs and existing mini-program APIs, improving development efficiency and reducing costs.

Common use cases include:

- Algorithm libraries
- Support for general instrumentation devices
- Custom functional modules

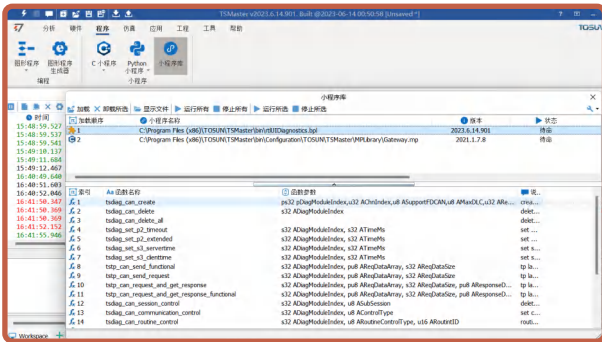

Graphical Programming

TSMaster includes a built-in graphical programming language that supports users in writing arbitrary logic. It supports subsystems, breakpoints, single-step debugging, and allows calls to any C/C++ functions. It is a versatile graphical programming language.

Using TSMaster's graphical programming module, users can access built-in features such as RBS (Residual Bus Simulation), CAN/CAN FD/LIN/FlexRay/Ethernet bus signals, system variables, and mini-program APIs. This enables process-oriented and graphical programming, greatly enhancing work efficiency.

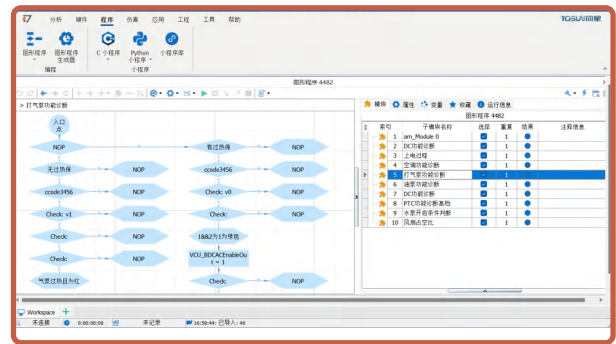

Graphical Program Generator

Developers can write test procedures in Excel and import them to automatically generate graphical programming workflows:

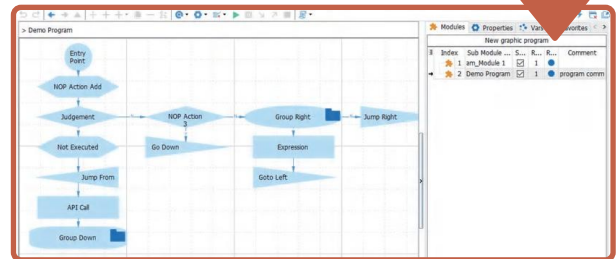

Analysis

Message Transmit

- Supports manual sending, shortcut key sending, and cyclic sending
- Supports signal generators capable of generating sine waves, square waves, triangle waves, and custom waveform data
- Supports adding custom messages and retrieving messages from the database
- Supports copying messages to C scripts for flexible and convenient message transmission

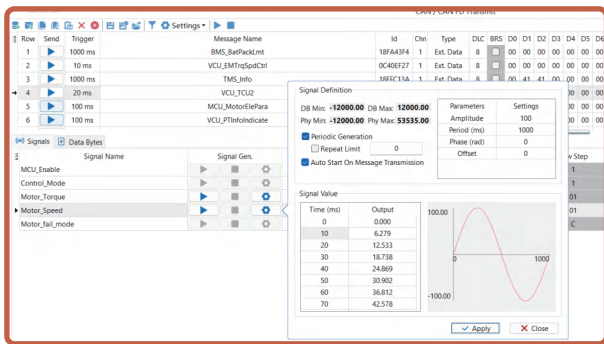

Message Monitoring

- Supports message display for communication protocols such as CAN FD, CAN, LIN, FlexRay, and Automotive Ethernet
- Supports both absolute and relative time display
- Supports scrolling display, fixed display, expanded view, and collapsed view
- Allows direct signal value viewing after DBC parsing
- Supports frame rate or message cycle display
- Supports channel filtering and ID filtering
- Supports bold display for changing message bytes

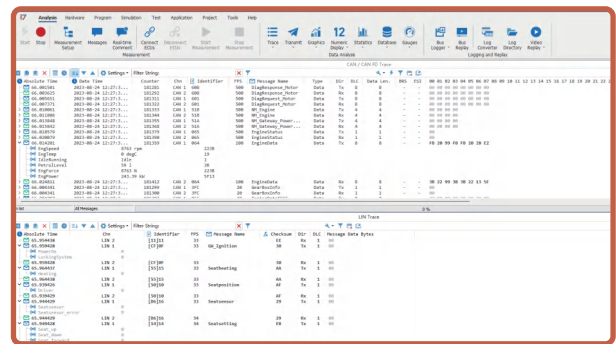

Graphical Curves and Numeric Display

Signals support Trace, numeric, and chart display. Users can create multiple chart, numeric, and Trace windows, with an unlimited number of signals added to each for monitoring. In the graphical curve module:

- Unlimited number of signals can be added without lag
- Signal Y-axis is flexibly configurable, supporting multi-axis and split display modes
- Can display precise data points instead of just vague curve shapes
- Supports bold display for changing message bytes

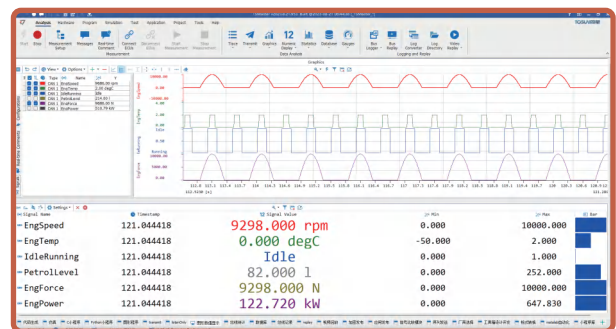

Bus Statistics

The CAN bus statistics feature includes: bus load rate, peak load rate, data frame rate, data frame count, error frame rate, error frame count, controller status, transmit error count, etc. These statistics can also be displayed on panels or charts through system variables.

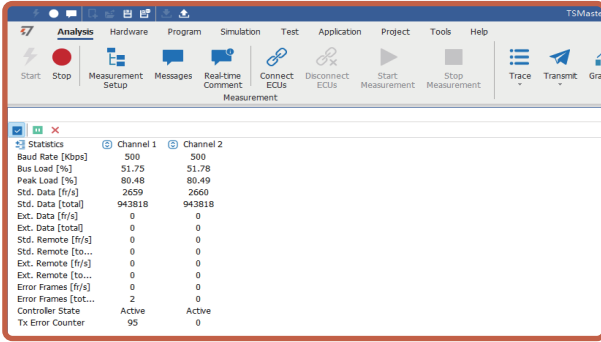

Message Replay

Message playback supports BLF and ASC formats, with both online and offline playback modes. Offline playback is equivalent to directly opening a file, with options for post-processing functions and playback range selection. Online playback sends messages through hardware according to defined rules and supports:

- Playback count and mode
- Start timing conditions
- Shortcut keys for start, stop, pause, and resume
- Pass/block filters
- Channel mapping

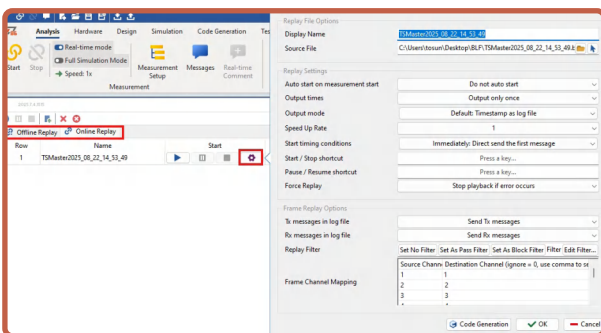

Database

Supports loading DBC/ARXML/LDF/XML database files. It also provides a structural view of the database, a signal communication matrix view, and a message communication matrix view. For ARXML databases, multiplexed signal parsing is supported. In addition to traditional button-based importing, drag-and-drop of database files into the workspace is also supported.

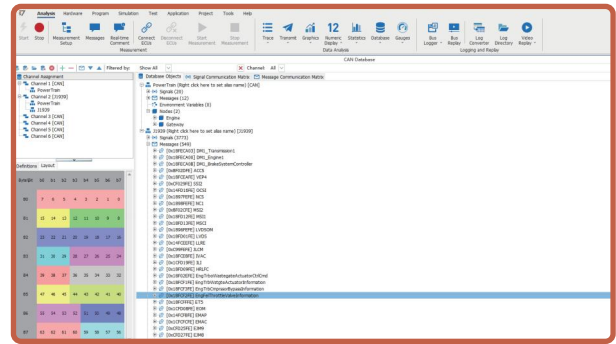

Bus Logging

By default, logs are saved as BLF files, and can later be converted to ASC/CSV/MAT formats.

- Can be configured to start logging automatically when analysis begins
- Supports unlimited logging
- Can be set to automatically create a new file after logging 5 million messages per file
- Can be set to create a new file after each file reaches 500 MB
- File naming rules are configurable; filenames can include: username, system time, start time, project name, etc

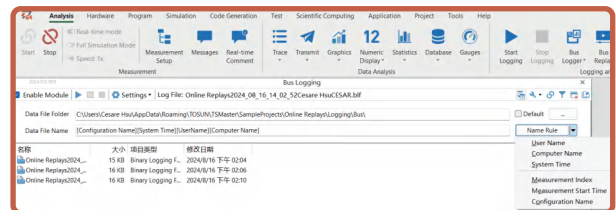

Video Replay

Supports common video formats such as MP4, AVI, and WMV.

Can be linked to the bus playback engine with configurable time offset, enabling synchronized analysis of video and bus data.

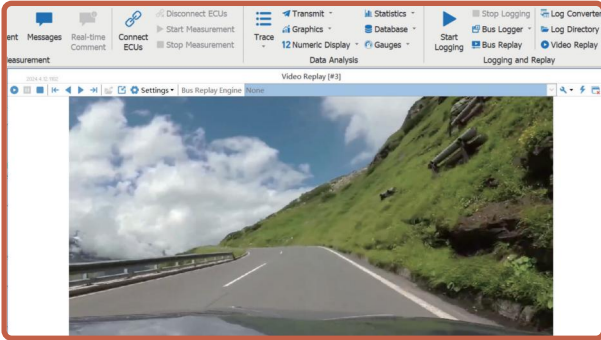

GPS Replay

TSMaster includes a built-in GPS data playback and analysis module.

It can be linked with bus message data to perform synchronized analysis of GPS and bus data.

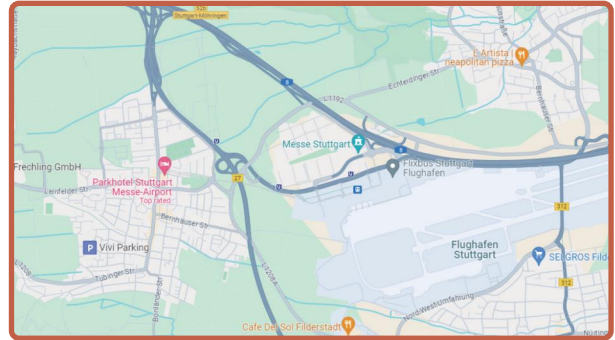

Test System

Test System

The TSMaster software features an open architecture. In addition to supporting Tongxing (SameStar) hardware, it can integrate a wide range of external instruments and automotive sensor simulators via mini-programs. Combined with C scripts for test case development, users can easily build automated testing systems and export test reports in user-defined formats.

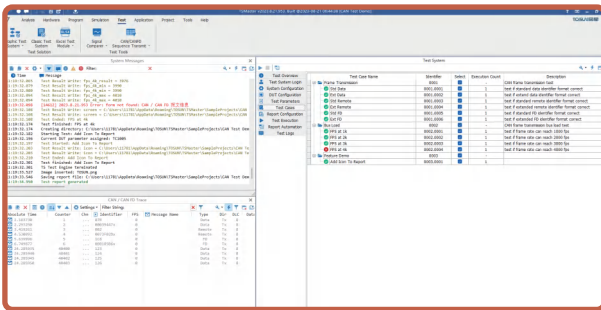

Excel Test Module

With the dedicated Excel testing module and its related functions, users can import test cases written in Excel to perform testing. After execution, test results are displayed directly and can also be used to generate test reports.

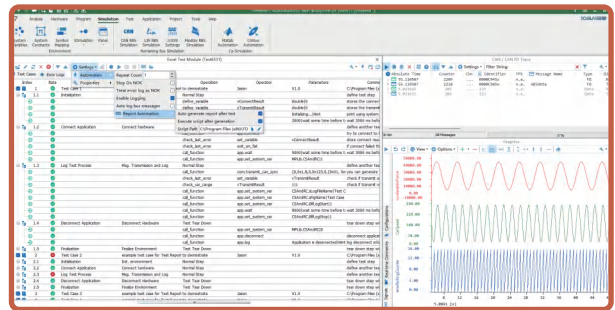

Flowchart-Based Testing System

The Flowchart-Based Testing System is fundamentally similar to the graphical programming module and can also be used as a testing system with support for automatic test report generation.

Its advantages include:

- Visualized execution process
- Flowchart-based test logic
- Similar to Stateflow
- Supports breakpoints
- Supports step-by-step execution
- Editable from PC
- Logs each execution step
- Easy API integration

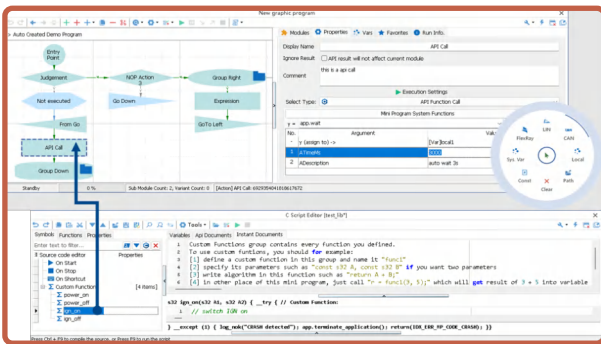

Signal Comparison Module

Supports real-time monitoring and analysis of thousands of signals simultaneously with smooth performance and low CPU usage. Built-in signal value calculation and judgment features allow users to intuitively observe whether signals remain within the expected range.

Includes built-in parsers for CAN FD/CAN/LIN and sensor variables, and is compatible with DBC, LDF, FIBEX, and ARXML databases.

Signals can be freely dragged and dropped across the same or different panels.

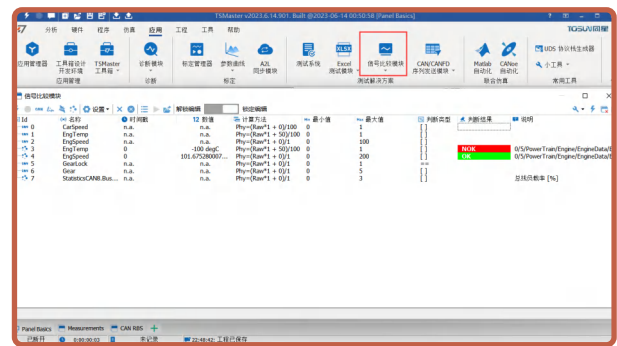

Signal Testing System

The Signal Testing System is used to analyze signal characteristics. Supported signal types include system variable signals, bus signals, and test signals. It can detect features such as rising/falling edges, level holding, and signal changes. The configuration UI is shown as follows:

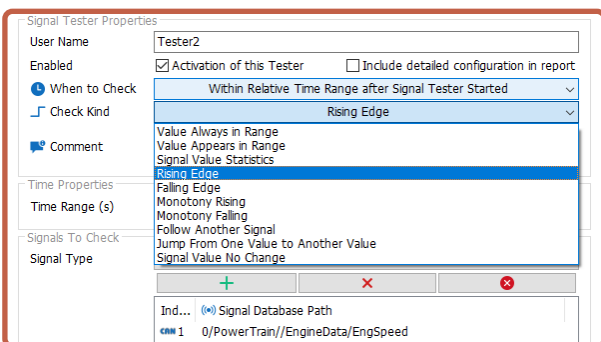

Sequence Transmission Function

The Sequence Transmission module enables predefined sequences of CAN/CAN FD messages to be sent without the need for scripting. This module is commonly used for sending control messages in a specific order or loop to verify product functionality.

It supports the creation of multiple transmission sequences. Each sequence can include both raw messages and database messages, and the number of loops can be configured. The sequence transmission process can be registered as a system variable, allowing it to be called and controlled by other modules, such as C mini-programs.

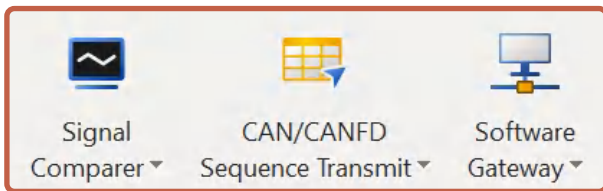
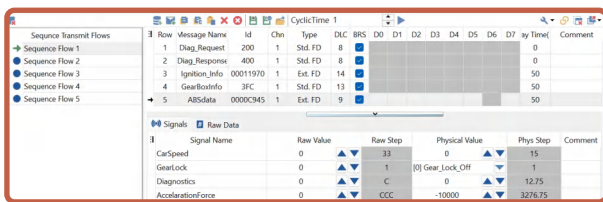

Software Gateway

The Software Gateway module provides a graphical, code-free interface for configuring message mapping and forwarding. Users can create forwarding lists and configure source and target channels for gateway messages, enabling real-time forwarding of received messages from the source channel to the target channel.

Gateway message data can be forwarded in a 1:1 manner or modified using a signal generator. The signal generator supports sine wave, ramp, pulse, range, toggle, random, custom, and system variable signals. This module can be used to inject fault data during message forwarding or to add and transmit changing signals such as a Rolling Counter.

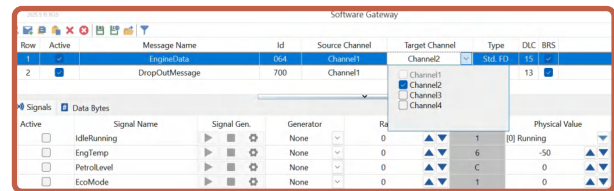
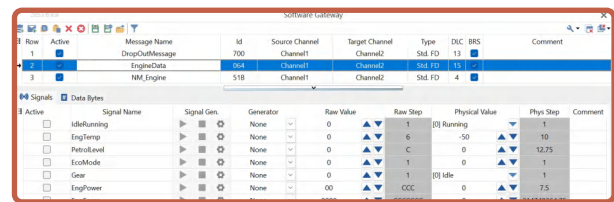

Diagnostic

TSMaster's diagnostic features support the configuration of diagnostic parameters and services, UDS-based Flash Bootloader setup, and the implementation of automated diagnostics. ODX and CDD files are supported.

With minimal or even zero coding, TSMaster enables efficient development of diagnostic workflows. Developers only need to be familiar with the diagnostic process, allowing seamless integration across R&D, production, and after-sales service.

Diagnostic Parameter Configuration

Transport Layer Parameters: Configure bus type, various IDs, channel DLC, intervals, etc.
Service Layer Parameters: Configure P2 timing parameters, tester online settings, seed & key, etc.

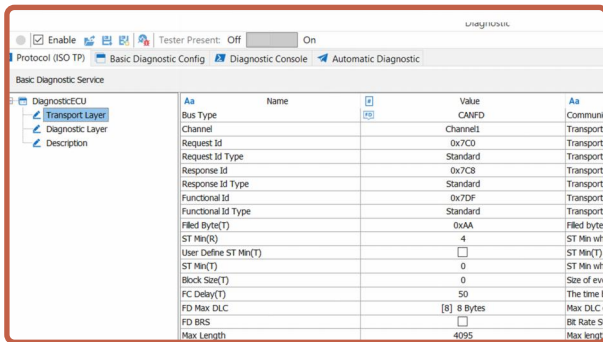

Diagnostic Seed&Key

TSMaster supports direct import of Seed&Key DLLs and includes a built-in SeedKey algorithm editor, allowing users to implement SeedKey algorithms without relying on external development tools.

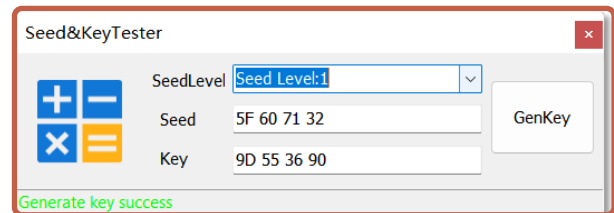
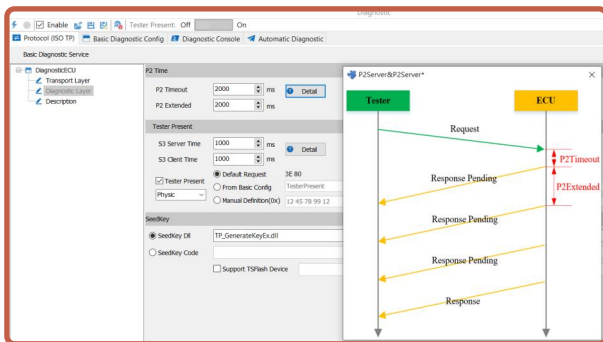
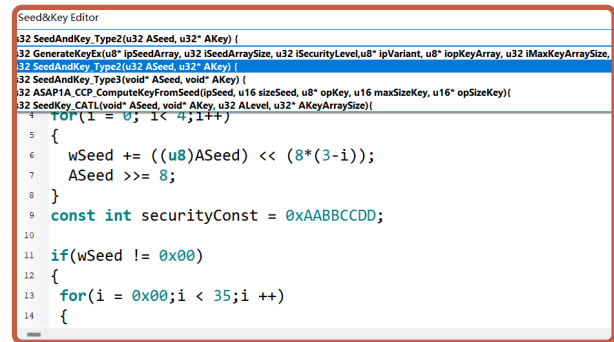

Database-Based Diagnostics

Supports importing diagnostic database files such as ODX, PDX, and CDD, with options to select different MCU variable objects.



Automated Diagnostic Workflow

TSMaster allows users to customize workflows, define diagnostic services directly, and freely drag and arrange configured services. This makes it easy to build various Flash Bootloader flashing processes.

Index	Type	ServiceName	Address	Request(DI)	Response(DI)	Delay	Property
1	Normal	ExtendedSession	Physic: 10 03	Req: Response 10 03	Res: Response 10 03	50	Retry(0)(Sec)
2	Normal	ClearDTC	Physic: 18 03	Req: Response 18 03	Res: Response 18 03	50	Retry(0)(Sec)
3	Normal	DisableRx	Physic: 28 03 01	Req: Response 28 03 01	Res: Response 28 03 01	50	Retry(0)(Sec)
4	Normal	ReadDataByCP_188	Physic: 22 F1 08	Req: Response 22 F1 08	Res: Response 22 F1 08	50	Retry(0)(Sec)
5	Normal	Session2	Physic: 10 02	Req: Response 10 02	Res: Response 10 02	50	Retry(0)(Sec)
6	Service2	Service2	Physic: SeedLevel3KeyLevel4	Req: Response 10 02	Res: Response 10 02	50	Retry(0)(Sec)
7	Normal	WriteDataByCP_190	Physic: 22 F1 00 50 24 21 1E 45	Req: Response 22 F1 00	Res: Response 22 F1 00	50	Retry(0)(Sec)
8	Normal	DownloadFile	Physic: 0_40_1_40_1	Req: Response 22 F1 00	Res: Response 22 F1 00	50	Retry(0)(Sec)
9	Normal	FlashErase	Physic: 31 01 FF 00 40 00 80 00 00 00 C0 00 00	Req: Response 31 01	Res: Response 31 01	50	Retry(0)(Sec)
10	Normal	ReadDataByCP_190	Physic: 22 F1 00 50 24 21 1E 45	Req: Response 22 F1 00	Res: Response 22 F1 00	50	Retry(0)(Sec)
11	Normal	ECU/Reset	Physic: 11 01	Req: Response 11 01	Res: Response 11 01	1000	Retry(0)(Sec)
12	Normal	ExtendedSession	Physic: 10 03	Req: Response 10 03	Res: Response 10 03	50	Retry(0)(Sec)
13	Normal	EnableRx	Physic: 28 03 01	Req: Response 28 03 01	Res: Response 28 03 01	50	Retry(0)(Sec)

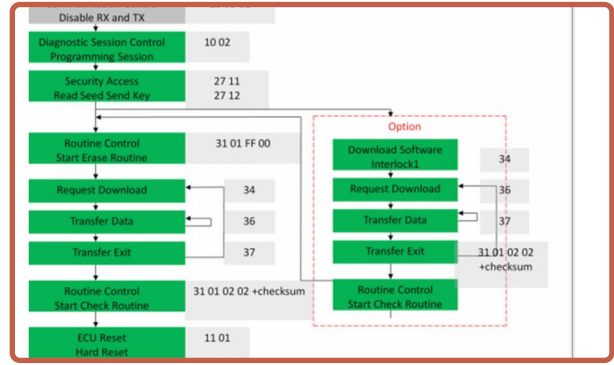

Typical Application

UDS-based Flash Bootloader flashing. Combined with modules such as Panel, users can create Flash Bootloader flashing interfaces within the software without writing scripts, enabling flexible applications for different use cases.

- Diagnostics + Panel PC → based Flashing Software
- Diagnostics + Panel + COM → Production Line Flashing Software
- Diagnostics + Panel + COM + Application Deployment → After-sales Flashing Software
- Diagnostics + TFI011 → Handheld Flashing Device
- Diagnostics + CAN Device with Wireless Module → Remote Flashing Device



Configure the flashing process in TSMaster



Perform online flashing via connected CAN/LIN tools



Download the configuration to a handheld flashing device for offline flashing



Use a tablet with TSMaster to connect to the CAN tool via WiFi for flashing

Vehicle/ECU

DoIP Functionality and Flashing

TSMaster's DoIP function supports both standard Ethernet transmission (Tx) and automotive Ethernet (T1). The configuration and usage are largely consistent with UDS diagnostic functions over CAN.

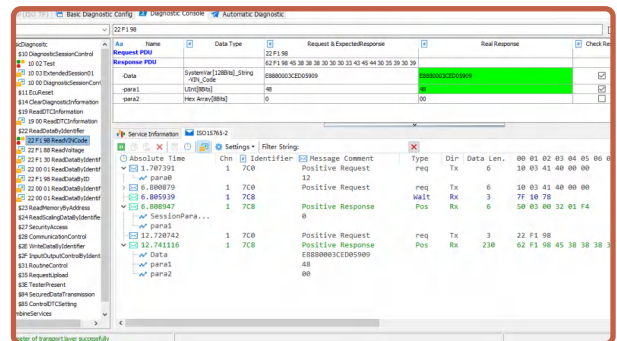
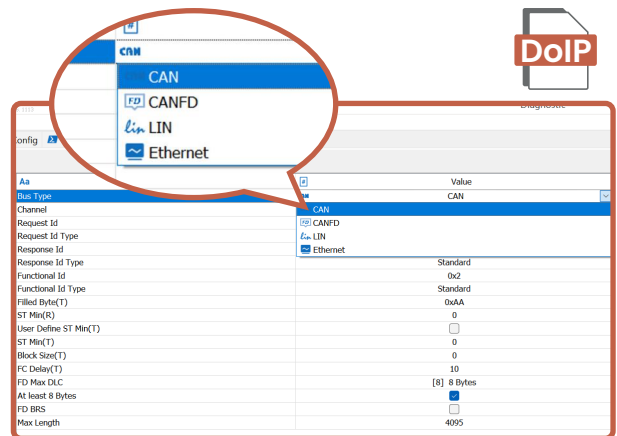

Calibration

Calibration Environment and Measurement Functions

- TSMaster supports XCP and CCP calibration
- Supports importing A2L files and variable parsing
- Supports simultaneous calibration and measurement across multiple channels, up to 64 channels
- Supports loading BIN/SI9/HEX/MOT files
- Supports Polling, dynamic DAQ, and static DAQ measurement modes
- Supports numerical display, graphical curves, and panel controls for signal observation
- Supports MDF/MF4 format recording and playback
- Supports unified timestamp recording and playback for calibration signals and bus signals

Calibration Functions and Data Management

- Supports both online and offline calibration
- Supports parameter, array, curve, and map signal types for calibration
- Supports characteristic parameter curves and 3D views of maps
- Supports importing and exporting calibration parameters in PAR, DCM, and HEX formats
- Supports automated calibration via COM service components
- Supports calibration data management, including comparison and analysis of multiple calibration datasets
- Supports XCP program protocol downloads
- Supports uploading calibration data from the working page or reference page
- Supports merging calibration data areas with application program areas

Automated Calibration

- TSMaster integrates message analysis, diagnostics, calibration, and system variable data into a single platform, enabling synchronized data analysis
- Automated calibration can also be achieved via COM component calls
- Typical applications: In production lines, laboratories, and other scenarios, user-developed applications can invoke TSMaster software via COM component interfaces to perform automated calibration and flashing

User-developed applications



Invoke via COM components to achieve automated calibration

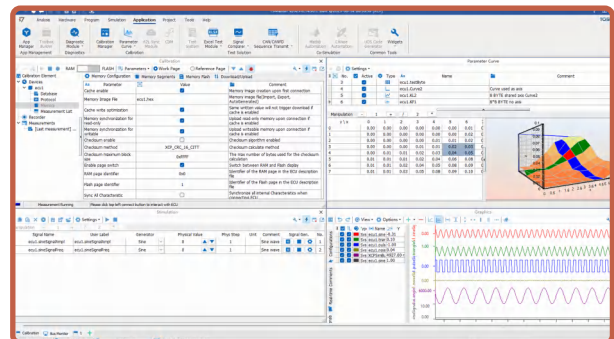

Scan the QR code to view detailed feature descriptions

Remote Calibration

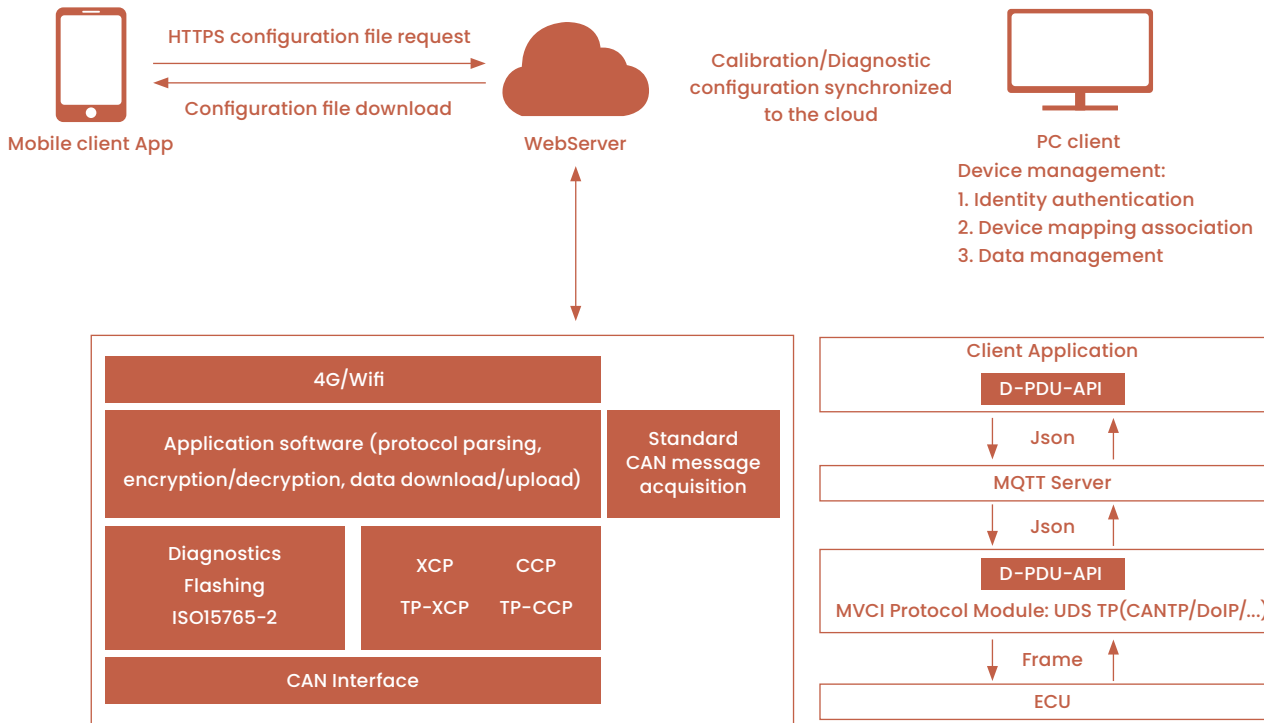

Seamless Engineering Lifecycle

The configuration file suffix for TSMaster engineering files is .T7z, which supports compressed and encrypted configuration files. A T7z file contains all the contents of the current configuration: forms, information on the forms, database, panels, C scripts, etc.

Encrypted release and application release are mainly used to streamline the entire process flow including development, testing, production, and after-sales. After development and configuration are completed, there is no need for customized non-standard software. The encrypted release and application release functions can be used to publish and provide the files for subsequent stages.

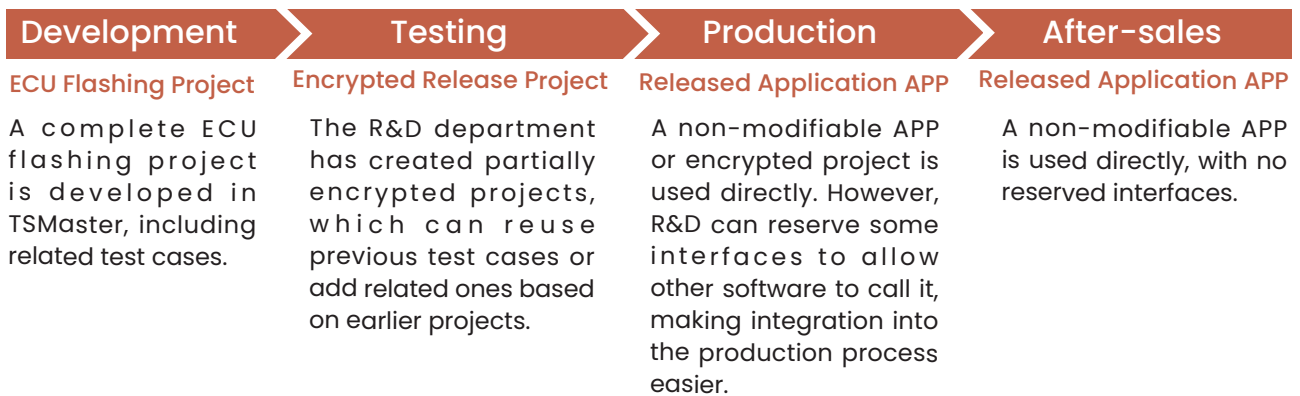

Encrypted Release

Encrypts internal modules of the engineering configuration, such as DBC and script modules. The released engineering file can only be opened and used on the corresponding hardware with the correct password.

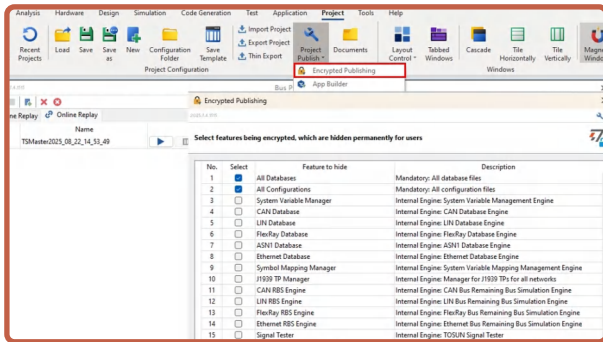

App Builder

Customizes the release form interface based on TSMaster, allowing users to select which modules and forms to display and execute. Users can only use the obtained engineering files but cannot edit them, providing a usage experience similar to customized software interfaces. By using TSMaster's encrypted release and application release, product development personnel only need to develop a diagnostic-related program during the product development phase. Then, according to requirements, different licenses can be used to release software modules to the production line or after-sales, completing the full-process diagnostic development. This approach saves labor costs, reduces development stages, makes development time more controllable, and ensures security.

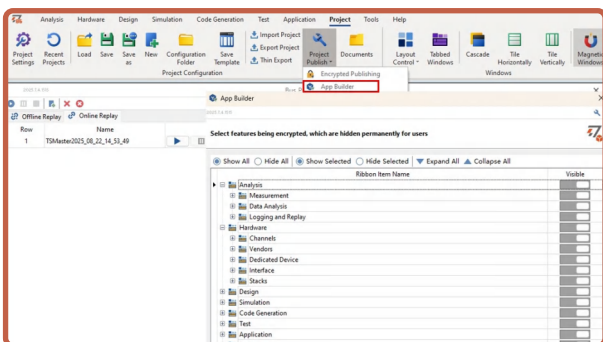

Additional Features

Model Block Diagram

The TSMaster Model Block Diagram module is a Simulink-like modeling module designed to support Model-Based Development (MBD). It allows users to build system models by dragging and dropping modules and connecting signal lines. It supports simulation of continuous-time, discrete-time, and hybrid systems.

Module Features

- **Rich Module Library:** Includes predefined modules in areas such as mathematical operations, signal processing, control systems, and communication systems
- **Hierarchical Modeling:** Supports creating hierarchical models through subsystems; multiple modules can be combined into subsystems; supports multi-level nested subsystems; enables creation of conditional execution subsystems (such as enable, trigger, etc.)
- **Simulation Capabilities:** Supports parallel running of subsystems with different sampling rates; automatically handles signal transmission between modules operating at different rates
- **Deep Integration:** Can directly read data from TSMaster system variables; simulation results can be exported as mbd files for analysis; related functions within the model block diagram can be called to operate TSMaster

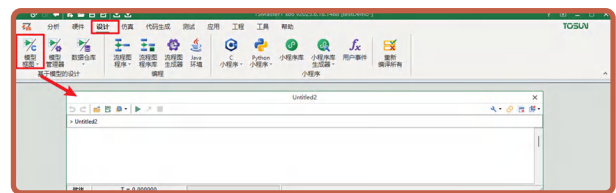

Real Vehicle Data Acquisition Mode

When Vehicle Measurement Mode is enabled, all channels automatically switch to listen-only mode. This mode is designed for scenarios where you're monitoring a real vehicle or network traffic without interference. Vehicle Measurement Mode takes the highest priority. It overrides the current hardware settings. Regardless of the existing configuration, once this mode is activated.

TSMaster will not actively transmit any messages. When enabled in the hardware settings, Vehicle Measurement Mode applies the following configurations:

CAN/CAN FD:

- Termination resistors are disabled to avoid affecting bus impedance
- Channels are set to listen-only mode to ensure no messages are sent, even if simulation modules are active

LIN:

- Termination is configured as a slave node
- Operates in monitor mode (not in master/slave mode)

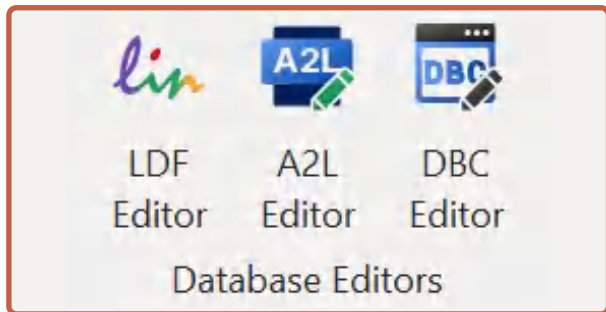
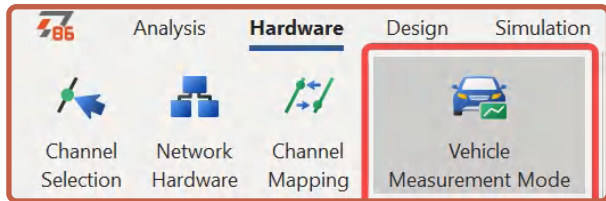

Support for Third-Party Hardware

TSMaster highly abstracts the measurement behavior of measurement tools, enabling the software to support a wide range of well-known bus tool brands—such as Vector, PEAK, Kvaser, ICS, and ZLG—without any modification to the software itself. It also supports oscilloscopes, waveform generators, digital multimeters, programmable power supplies, and other measurement and testing instruments from major manufacturers such as Tektronix, Keysight, and LeCroy.

Even if new measurement and testing instruments appear on the market, TSMaster can integrate them into the software platform without changing the core software.

LDF Editor

The main functions of the LDF Editor include viewing, creating, and modifying LDF files.

The “Create New LDF File” function covers nodes, frames (supporting unconditional frames, diagnostic frames, etc.), signals, schedule tables, system variables, and more.

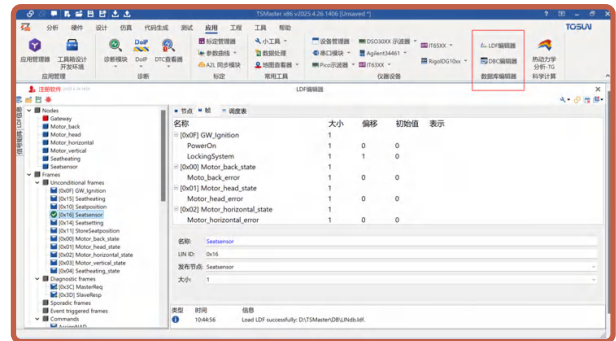

A2L Editor

The main functions of the A2L Editor include viewing, creating, and modifying A2L files.

It supports importing ELF files and then exporting new A2L files.

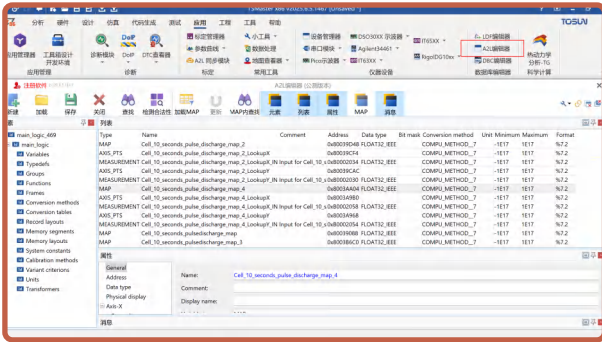

DBC Editor

The main functions of the DBC Editor include viewing, creating, and modifying DBC files.

The "Create New DBC File" function covers nodes, messages, signals, system variables, and more.

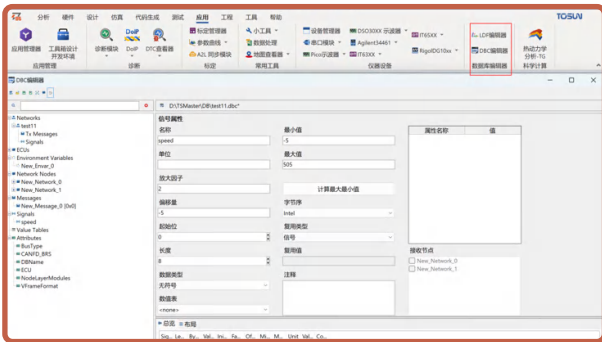

Toolbox Design and Development Environment

The TSMaster software architecture supports dynamic loading of toolboxes and provides framework-level functional support for their development. Key functions such as the calibration module, diagnostic module, and testing system module are all implemented in the form of toolboxes.

Users can develop their own software systems to run within TSMaster based on the toolbox architecture, enabling TSMaster to support not only in-vehicle networks but also industrial, medical, and other fields.

Any developer can use Python to design a professional TSMaster user interface and integrate it into their own projects to meet specific application needs, messages, signals, system variables, and more.

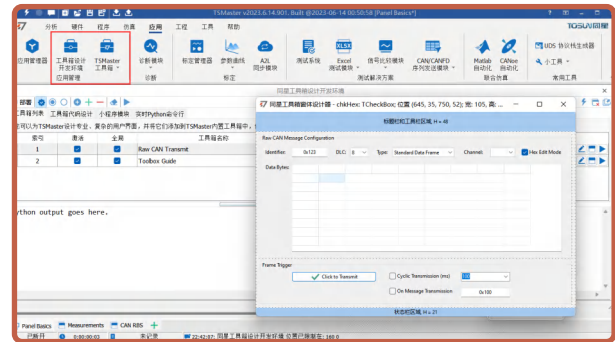

Comparison Between Toolbox and Panel:

Item	Panel	Toolbox
Features	Panels are mainly composed of buttons, labels, and selection boxes. They are linked to system variables, RBS modules, and scripts through association information	Built-in Python-based graphical Integrated Development Environment (IDE) that allows users to develop window modules and call TSMaster's built-in API functions
Use Cases	Panel works with RBS simulation Panel works with scripting tools	Used when more complex logic is required and the interface needs to present more elements
Target Users	Suitable for testers without coding background	Requires developers with Python knowledge

TSMaster COM API

Calling TSMaster through COM components means it can be invoked from software written in other programming languages on Windows, thereby extending more application scenarios.

Typical Applications

In production lines, laboratories, and similar environments, users can use their own applications to call TSMaster via the COM interface, enabling automated diagnostics and calibration.

Automotive File Conversion Function

TSMaster supports conversion between multiple commonly used file formats: DBC / ARXML / XLSX / XLS / DBF / YAL / YAML / SYM / CSV / BLF / ASC / JSON / FIBEX / MAT ...

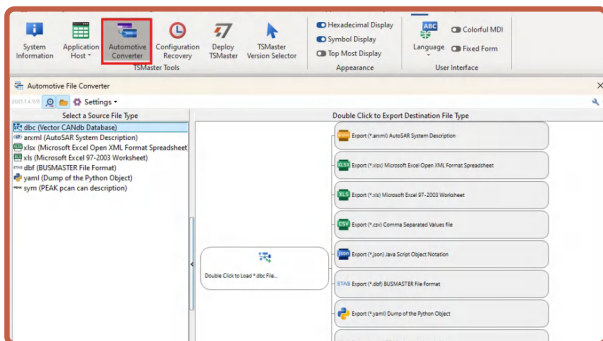

Multi-Language Support

The TSMaster software interface, built-in panels, and toolbox modules all support multiple languages, facilitating collaborative development among engineers worldwide.

Supported languages include Simplified Chinese, Traditional Chinese, English, Spanish, French, Japanese, Korean, Vietnamese, and more.

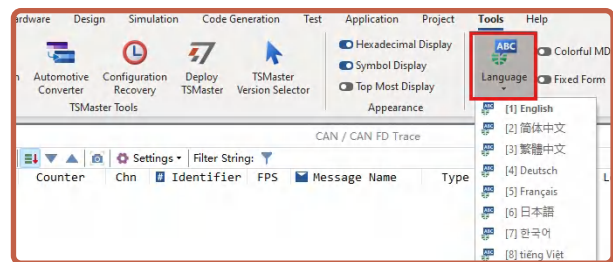

Instrument and Equipment Management

- Default integration of recommended models for mainstream testing instruments such as serial ports, oscilloscopes, programmable multimeters, programmable power supplies, and signal generators
- In addition to a user-friendly operation UI, a rich set of programmable API interfaces is provided for each type of programmable device
- A MiniSDK development environment is provided, allowing users to integrate their own devices

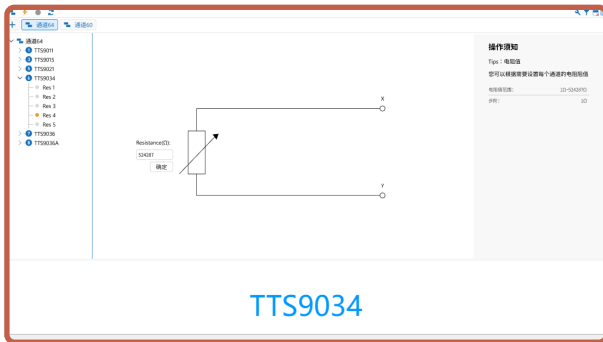
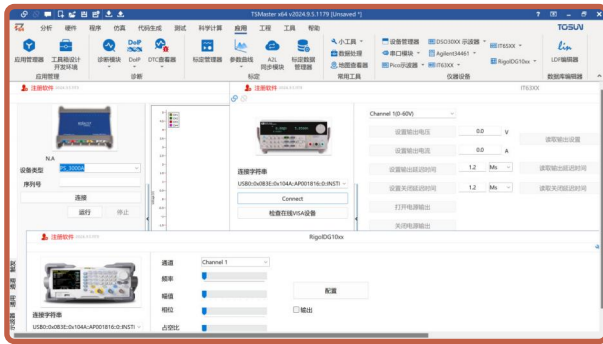

Hardware



CAN / CAN FD / LIN

PC Interface	USB 2.0 interface
CAN Interface	DB9 interface
Driver	Driver-free design for Windows and Linux systems, ensuring system compatibility
Secondary Development	Supports Python, LabView, C#, C++, etc., with sample code for some products
Buffer	Each channel supports a transmit buffer of up to 1000 CAN frames
CAN	Supports CAN 2.0 A and B protocols, compliant with the ISO 11898 1 standard, with baud rates from 125 Kbps to 1 Mbps
CAN FD	Supports CAN FD that complies with both ISO and non ISO standards, with baud rates from 125 Kbps to 8 Mbps
LIN	Supports LIN 1.3 and 2.0, with a baud rate ranging from 0 to 20 Kbps
Schedule Table	Supports LDF files and running scheduling tables, or configuring scheduling tables independently
Timestamp Accuracy	1 μ s, hardware message timestamp
Isolation	CAN channel DC 2500 V isolation
Termination Resistor	Built-in 120 Ω CAN termination resistor, software configurable

Classic Application

- Bus data monitoring and analysis
- Vehicle network node simulation
- ECU node and system-related testing
- UDS diagnostic testing
- ECU flashing based on UDS
- ECU or whole-vehicle calibration and flashing



Product Introduction

New



TL1001
1 channel LIN to USB interface

Fast



TL1011
1 channel fast LIN bus to USB interface

New



TC1021
UART-on-CAN device

New



TC1018Pro
12 channel CAN FD bus and I/O interfaces

New



TC1038Pro
12 channel CAN FD, 12 channel LIN,
2 channel FlexRay bus device
(supports 4 digital I/Os and 3 analog I/Os)

New



TC1055Pro
4 channel Automotive Ethernet, 4 channel CAN
FD, 2 channel LIN, 2 channel TX bus device,
(supporting 4 digital I/Os and 3 analog I/Os)

* Pro version products are equipped with IO, high-precision cyclic messaging, self-ACK, multi-device time synchronization, and other functions.



TL1021

UART On LIN device



TC1001

1 channel CAN to USB interface



TC1011

1 channel CAN FD bus interface



TC1012P

1 channel CAN FD/LIN bus interface



TC1013

2 channel CAN FD bus interface

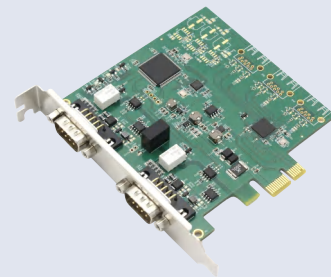

TP1013

2 channel CAN FD to PCIe Interface



MPI013

2 Channel CAN FD to miniPCle Interface



TC1014

4 channel CAN FD bus interface



TC1014Pro

4 channel CAN FD to USB interface
(supports 4 digital I/Os and 3 analog I/Os)



TC1016P

2 channel LIN,
4 channel CAN FD to USB interface



TC1017

8 channel CAN FD to USB interface



TC1018

12 channel CAN FD to USB interface



TC1018Pro

12 channel CAN FD bus and I/O interfaces



TC1026P

1 channel CAN FD,
6 channel LIN to USB interface

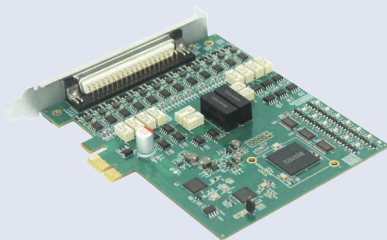

TP1018

12 channel CAN FD to PCIe interface

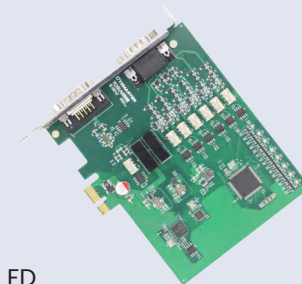

TP1026

1 channel CAN FD
6 channel LIN to PCIe interface

FlexRay



TC1034

2 channels of CAN FD/FlexRay to USB interface



TC1034Pro+

2 channels of CAN FD/FlexRay to PCIe interface



TC1038Pro

2 channel FlexRay,
12 channel CAN FD, 12 channel LIN bus device
(supports 4 digital I/Os, 3 analog I/Os)



TC1034

2 channel FlexRay,
2 channel CAN FD bus device
(supports 4 digital I/Os, 3 analog I/Os)

Features

- μ s-level hardware message timestamping, meeting advanced requirements
- Driver-free design for Windows/Linux, providing excellent system compatibility
- Equipped with auxiliary communication controller, no additional nodes required for cold start
- Built-in 120 Ω termination resistor for CAN, configurable via software
- Built-in 100 Ω termination resistor for FlexRay, configurable via software
- Pro version products support multi-device hardware synchronization



Main Functions

- Flexible configuration of communication controller buffers
- Detection of idle frames
- Composite communication mode composed of multiple cycles (Cycle Multiplexing)
- Supports frame payloads up to 254 bytes
- Supports PDUs
- Startup monitoring function
- FlexRay message recording and playback
- FlexRay channels can be used as independent FlexRay nodes in parallel

Classic Application

- Flexible analysis of FlexRay bus
- Precise timing analysis of bus communication data
- ECU testing, analysis, and gateway applications
- Various automated test benches

Ethernet



TE1021

1 channel
100/1000Base-T1 to 100/1000Base-Tx interface



TE1051

1 channel
automotive Ethernet to USB interface



TE1105

5 Port automotive Ethernet switch



New

TC1055Pro

4 channel automotive Ethernet, 2 TX,
4 CAN FD, 2 LIN to Ethernet/USB interface

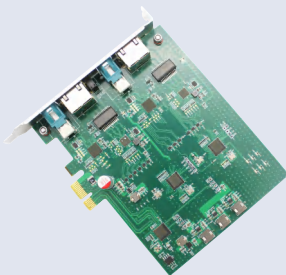

TP1051

2 channel
automotive Ethernet to PCIe interface

Classic Application

- Automotive Ethernet communication testing
- ECU flashing (based on UDS or DoIP)
- Automotive Ethernet bus simulation
- ECU-level / system-level automated testing
- Automotive Ethernet data monitoring and analysis

* Pro version products are equipped with IO, high-precision cyclic messaging, self-ACK, multi-device time synchronization, and other functions.

SENT/PSI5

TC4016

20 channel SENT, 16 channel PSI5,
2 channel CAN FD to Ethernet interface
(supports 4 digital I/O and 3 analog I/O)



New

SENT Parameters

- Idle polarity: High level
- Tick time range: 3 ~ 50 μ s
- Nibble count range: 0 ~ 8 nibble
- Data types: Fast channel data & Slow channel data

PSI5 Parameters

- Channel modes: Synchronous / Asynchronous
- Bus supply voltage: 5.15 V / 6.65 V / 7.70 V
- Comparator threshold current: 13 mA / 26 mA
- Baud rate: 125 kbps / 189 kbps
- Maximum slot length: 33 bits
- Slot time range: 0 ~ 480 μ s
- Error checking: Parity / CRC

Datalogger



Tlog1002

2 channel CAN FD, 2 channel LIN bus logger
(supports 3 digital I/Os, 2 analog outputs)



Tlog1004

4 channel CAN FD, 2 channel LIN bus logger
(supports 2 digital I/Os, 1 analog input)

Tlog1039

3 channel Ethernet, 12 channel CAN FD,
10 channel LIN, 2 channel FlexRay bus logger
(supports 4 digital I/Os, 3 analog I/Os)



New

CAN/CAN FD to Fiber Optic Device

New



TO1013

2 channel CAN FD to fiber optic device

Classic Application

- Product EMC testing
- CAN Bus Communication under Complex Electromagnetic Conditions

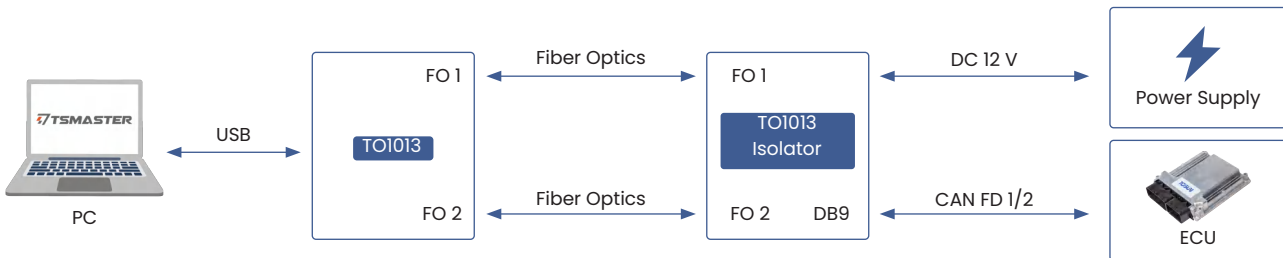

CAN Trigger

TC201

GPS and IMU data to CAN FD/CAN device



Features

- Electrical isolation
- CAN signal trigger
- Waveform conversion

GPS to CAN FD/CAN Device



TM2101

GPS/IMU to CAN/CAN FD converter

Features

- Supports custom IDs and DBC generation
- Configurable GPS/IMU data type and reporting intervals
- Supports multiple GNSS systems (BDS/GPS/GLONASS)
- Outputs acceleration and angular velocity via built-in IM

High Precision Time Sync Device



TSync01

High-precision time synchronization device

Features

- μ s-level hardware timestamps for time-sensitive applications
- Supports multiple GNSS systems (BDS/GPS/GLONASS)
- Flexible sync modes: relative or absolute

Offline Gateway



GW2112

2 channel CAN FD/CAN offline gateway

Features

- CAN/CAN FD/LIN conversion, message filtering
- μ s-level hardware timestamps, self-ACK
- BLF/ASC logging & replay, relay expansion



GW2208

8 channel CAN FD/CAN,
2 channel LIN offline gateway
(Supports 2 digital outputs, 4 digital inputs)

Features

- CAN/CAN FD conversion & routing
- 20,000 fps forwarding (<0.5 ms latency)
- Custom functions, encrypted configuration

CAN/CAN FD Disturbance device



TH7011

CAN/CAN FD disturbance interface



TH7012

CAN FD/LIN disturbance interface

Features	TH7011	TH7012
Interference on specific bits of CAN/CAN FD frames	✓	✓
Multiple trigger modes: frame, error frame, software	✓	✓
Custom sequence up to 65,536 points, 5 ns	✓	✓
CAN error frame level detection	✓	✓
CAN interference count statistics	✓	✓
CAN bit-level interference: dominant, recessive, flip	✓	✓
Configure & send interference sequences	✓	✓
CAN frame trigger level length configuration	✓	✓
CAN bus bit width tolerance testing	✓	✓
CAN bus bus-off behavior testing	✓	✓
Sampling point testing	✓	✓
Scope waveform capture	✓	✓
Interference on specific bits of LIN frames		✓
LIN interference count statistics		✓
LIN bit-level interference: dominant, recessive, flip		✓
LIN frame interference level length configuration		✓
LIN transmission with configurable frame header		✓
Transmission of incomplete LIN frames		✓
LIN ±14% baud rate offset		✓
Measurement of LIN frame timeslot duration		✓
LIN trigger output function		✓

Handheld UDS Flashing Device



TF1011

1 channel CAN FD,
Handheld offline flashing device

Features

- DB9-powered, CAN DC2500V isolated
- UDS/Flash Bootloader flows via TSMaster GUI
- Supports seedkey & Infineon UART-on-CAN/
TLE989x BootRAM

Classic Application

- Offline UDS diagnostics
- Offline UDS Flash Bootloader updates

TIO Test Module



TIO9011

12 channel digital input/output module



TIO9015

8 channel analog input/output module



TIO9036

6 channel programmable
resistance simulation module



TIO9045

18 channel general-purpose relay module
resistance simulation module

Classic Application

- Vehicle data acquisition
- Vehicle energy flow management
- Road testing

Connection Diagram

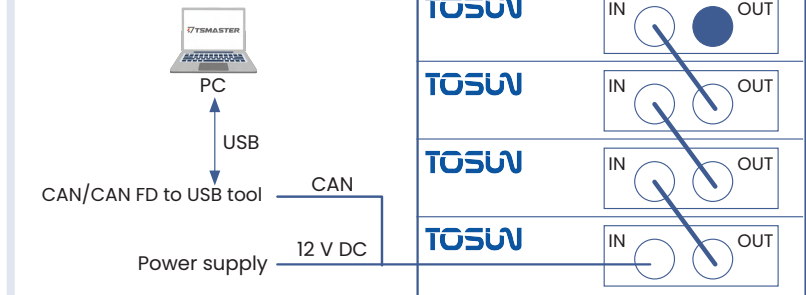

TTS Test System

- All in one design:
CAN FD / CAN / In-vehicle Ethernet / FlexRay / LIN
communication boards
Digital input/output boards
Analog input/output boards
Relay, fault injection boards, etc
Resistors for simulating sensors
- Minimal wiring work for test setup
- Voltage range suitable for automotive applications
- Seamless integration into TSMaster



TTS9011

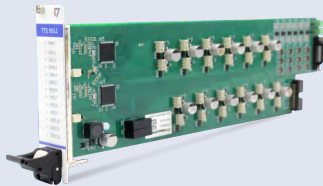

Digital I/O Board

TTS9036

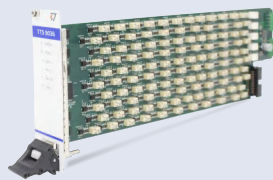

Resistor Board

TTS9021



Fault Injection Board

TTS1016Pro



4/2 CAN FD/LIN

TTS1026Pro

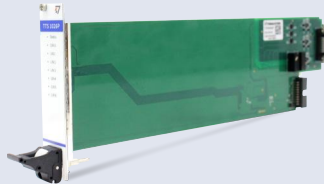

1/6 CAN FD/LIN

TTS1034

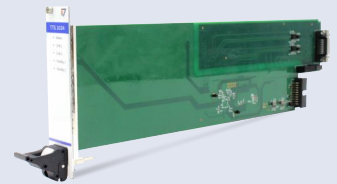

12 CAN FD

TTS9015



Analog Board

TTS1018

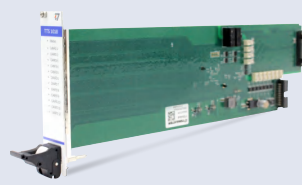

Dual channel CAN FD/FlexRay

TTS9045



General Purpose Relay Board

Real Time Simulation Test System

XIL Cube Product Features

- Supports EtherCAT master functionality
- CPU: Intel(R) Core(TM) i5-10210U
- Memory: 16GB
- Storage: 256GB (SSD)
- Operating system: Windows 10 IoT LTSC

TIO9036

12 CAN FD, 12 LIN, 2 FlexRay
Multi bus simulation and testing device

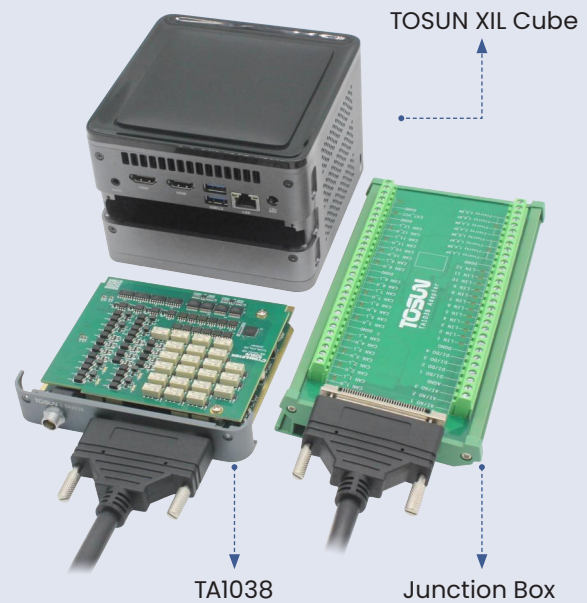

ECU Diagnostics and Flashing Solution

The TOSUN ECU diagnostics and flashing solution, based on TSMaster software, supports UDS services, ODX/PDX database import, Flash Bootloader programming, and automated testing. By combining software and hardware modules, it can be deployed as PC, production line, after-sales, handheld, or remote flashing tools.

Advantages

- Low/zero-code workflow development
- Cost-effective with TSMaster basic functions
- Supports CAN, CAN FD, LIN, DoIP, FlexRay
- Seamless UDS integration
- Compatible with Hex, S19, Bin, VBF formats
- Flexible control via GUI or API

Application Scenarios

- R&D: ECU flashing
- Production line: Integration into various automated systems
- After-sales: Updating ECU programs or OTA-based flashing

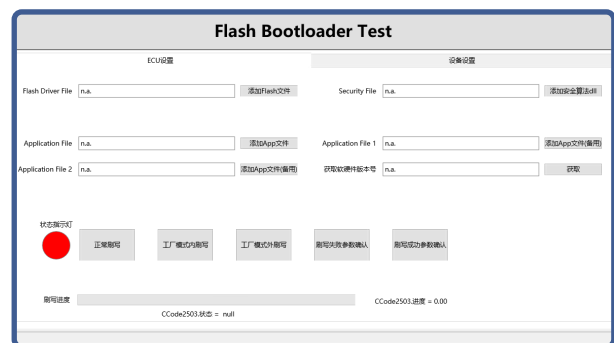
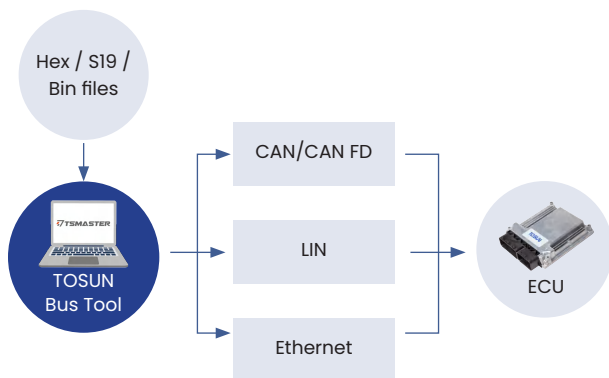

Bus Conformance Testing Solution

Bus Conformance Testing Solution

The CAN/CAN FD/LIN bus consistency testing system provides fully automated testing and report generation for automotive networks.

Based on TOSUN bus tools and TSMaster software, it supports physical, data link, and application-layer testing, including network management, UDS diagnostics, flashing, and gateway routing.



Advantages

- All-in-one automated testing with detailed reports
- Modular, extensible via TSMaster for custom test cases
- Standardized solution for OEM compliance verification

Key Features

- **Physical layer:** Voltage, timing, fault tolerance
- **Data link layer:** Bit timing, bus load, DLC
- **Interaction layer:** Message cycle, event-driven signals
- **LIN schedule testing:** Timing and order
- **Network/system-level:** Diagnostics, flashing, AUTOSAR NM, fault tolerance

Application Scenarios

- Physical layer testing
- Data link layer testing
- Interaction layer testing
- Fault tolerance testing
- Communication diagnostics testing
- CAN Bootloader flashing testing
- AUTOSAR_NM network management testing
- UDS diagnostic testing
- Gateway routing testing

Reference Standards

- ISO 11898
- ISO 16845
- SAE J1939
- AUTOSAR
- GMW 14241
- ISO 14229
- ISO 15765
- LIN 1.3/2.0/2.1/J2602
- SAE J2602
- GB/T 42691
- GEELY 3.0/3.5 Enterprise Standard
- SAIC Enterprise Standard
- BYD Enterprise Standard



HIL Simulation Solution

TSMaster-based HIL Simulation Solution TSMaster provides a rich set of built-in APIs, complete peripheral integration, and post-processing interfaces, offering low cost, fast deployment, and high automation.

Capabilities:

- Functional, diagnostic, and system integration testing of ECUs
- Simulation of vehicle I/O signals, bus nodes, power logic, process signals, and electrical faults
- Acquisition and analysis of controller control and drive signals for functional testing and fault diagnostics
- Single-ECU and multi-ECU joint testing
- Automated testing with report generation

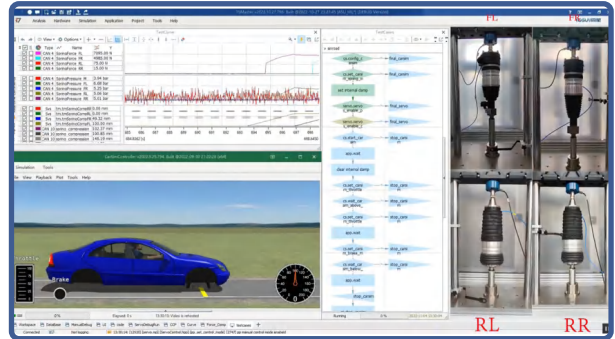

SecOC Testing Solution

TSMaster-based SecOC Testing Solution

As vehicles become more intelligent and connected, in-vehicle communication is increasingly vulnerable to malicious message injection or tampering, which can affect critical controls.

The TSMaster-based SecOC testing solution ensures message authenticity and integrity, using C scripts, Panel features, and CAN interfaces to handle:

- Message parsing, freshness value generation, and MAC calculation
- Secure message generation, sending, and validation
- Fault injection and security testing

TSMaster's scripting and graphical programming also enable end-to-end verification and fuzz testing, covering both development and production testing needs.

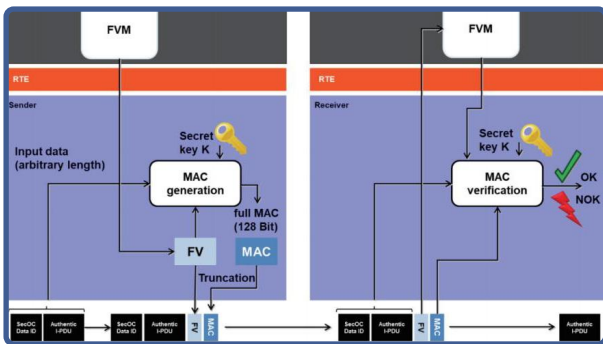

Charging Test System

Features

- Simulates AC (220V) and DC (up to 1000V) charging processes
- Supports GB/T34657.2-2017: Electric Vehicle Transmission Charging Interoperability Test, Part 2: Vehicle
- Supports GB/T34658-2017: Communication protocol consistency testing between off-board chargers and battery management systems
- Supports GB/T 27930
- Supports DBC status display, test cases, and customizable development via Python toolbox

Functions

- Consistency and interoperability testing for electric vehicles
- Fault simulation to improve vehicle compatibility and resistance to charging interference
- Automated testing, report generation, and software extension support

Application Scenarios

- On-board charger (OBC) functionality testing
- BMS charging tests
- After-sales charging scenarios, charger-end testing, and other standards



Test Items

Test Object: Electric Vehicle (DC Charging)	Test Object: Electric Vehicle (AC Charging)
<ul style="list-style-type: none"> • Vehicle charge and drive interlock • Connection confirmation • Self-check phase • Pre-charge readiness • Charging phase • Normal charge completion • Charge connection control timing • Insulation fault • Communication interruption • PE pin disconnection • Boundary voltage measurement at test point 2 • Auxiliary power boundary voltage measurementcustomizable development 	<ul style="list-style-type: none"> • Vehicle charge and drive interlock • Connection confirmation • Pre-charge readiness • Start and charging phase • Normal charge completion • Charge connection control timing • Switch S3 disconnection • CC circuit break • CP interruption • PWM duty cycle variation • PWM duty cycle overlimit • PWM frequency boundary test • CP loop boundary voltage measurement • CC loop boundary resistance measurement

EMB Calibration/Testing Solution

TOSUN self-developed EMB testing and calibration solution enables convenient parameter calibration and automated functional testing of EMBs using high-performance sensors, comprehensive analysis equipment, and TSMaster software. The solution is fully featured, stable, and has been applied in a leading domestic automaker.

Features

- Caliper profiling simulates real vehicle conditions: 25kN calipers support inner width $\geq 20\text{mm}$, 45kN calipers support inner width $\geq 30\text{mm}$; supports custom caliper profiling fixtures
- Standard 19-inch chassis, 12U height cabinet, equipped with programmable power supply, high-precision sensors, high-performance acquisition modules, and bus devices
- Supports test case creation, data acquisition, analysis, recording, and CCP/XCP calibration protocols
- Supports signal comparison modules, such as sine, square, and ramp pulse signals

Application Scenarios

- **R&D:** Functional testing
- **Laboratory:** Performance testing, salt spray testing, durability testing
- **Production line:** EOL (End-of-Line) inspection

Functions

- Automated testing of DUTs (Device Under Test)
- DUT calibration
- Performance testing
- Vibration testing



Motor Test System

This system enables accurate evaluation of motor performance and durability, supporting quality optimization and market competitiveness for new energy vehicles.

Benefits

- Ensures product quality and safety
- Meets energy efficiency standards
- Supports innovation and technical development

Functions

- Measures input parameters (voltage, current, power) and output indicators (torque, speed, efficiency)
- Generates performance characteristic curves
- Supports durability and efficiency testing

Applicable Motor Types

Single-phase & three-phase asynchronous motors, inverter motors, permanent magnet synchronous motors (including servo), EV drive motors, robotic joints, DC brushed/brushless motors, electric motorcycles, starters, gear reducers, and more.

Component Durability Test Solution

Durability testing is an important process to verify the service life of a product during its design phase. Typically, the testing department controls the test samples to undergo a specified number of operational cycles under nominal usage conditions (or slightly above nominal standards). The acceptance criteria usually require that, after testing, the samples retain their functionality, and no structural or electrical defects compromise user safety or could potentially lead to such issues due to strength degradation.

The goal of durability testing is to ensure that the product operates reliably and stably over long-term use, meeting user needs and expectations. Test results can be used to improve product design, optimize performance, and provide users with information regarding product reliability and durability.

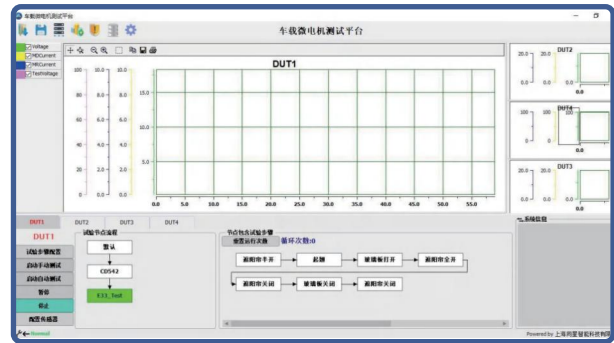

Test Content

- **Long-duration operation testing:** Run the product or device continuously for a set period to simulate actual usage conditions
- **Load testing:** Apply different loads and pressures to evaluate product performance
- **Environmental testing:** Expose the product or device to various environmental conditions, such as high/low temperature or high/low humidity, to assess its adaptability
- **Reliability testing:** Introduce faults or deliberate misuse during testing to simulate failures and evaluate recovery and reliability

Examples

- Sunroof durability testing
- Sunroof strength testing
- Sunshade durability testing
- Spoiler durability testing
- Camera durability testing
- Door durability testing
- Motor durability testing

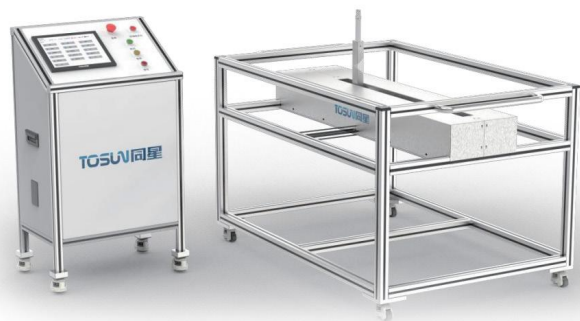

FCT Testing Solution

FCT (Functional Circuit Test) is an electronic and electrical functional testing method for automotive controller PCBA (assembled circuit boards). It is used to verify that all functions operate within normal parameters when the product is powered on. During the mass production of PCBA, various tests are required to ensure the boards meet quality standards.

FCT Test Equipment Architecture Diagram:

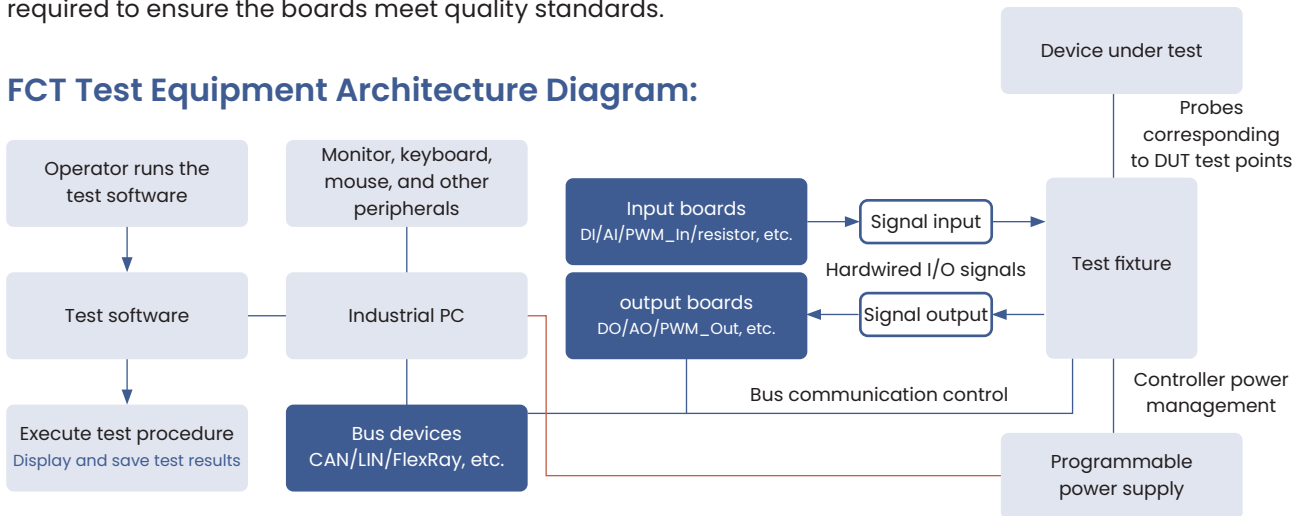

Functions

- Programming based on simulator/programmer
- Programming via CAN/LIN bus using UDS protocol
- Simulation and I/O signal testing
- UDS read/write testing
- Load testing
- Data storage



EOL End of Line Testing Solution

During the production of automotive electronic control products, the PCBA must first undergo programming and testing, followed by various assembly processes. Before the product leaves the production line, an EOL (End-of-Line) test is conducted. EOL testing serves as the final quality inspection step of the entire production line. The test covers electrical performance, software testing, program calibration, application updates, and other functional verifications.

Testing Items

- ECU communication testing
- ECU functional testing
- ECU fault simulation testing
- Performance evaluation
- Maintenance recommendations
- MES (Manufacturing Execution System) interaction
- Automatic test report generation

Tablet Solution

The TSMaster-based tablet is an integrated solution that combines the TSMaster software platform with multiple bus analysis hardware tools, effectively consolidating technical resources. This product solution focuses on addressing complex engineering challenges in industrial scenarios such as in-vehicle road testing, production line programming, and after-sales diagnostics. It provides users with efficient and precise technical support, helping engineers tackle a wide range of project challenges.

Case 1

Passenger Vehicle After-Sales Diagnostic Tool

Product Configuration: TPAD1003 + TC1114B

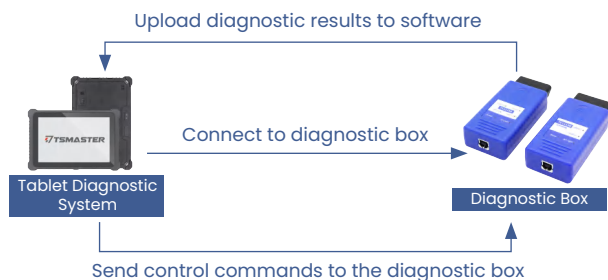

Main Functions

- After-sales diagnostic analyzer
- Read fault codes
- Clear fault codes
- Read freeze frame data
- Read live data stream
- Actuation tests
- Data stream storage
- Read freeze frame data (duplicate removed if needed)
- Maintenance manual guidance
- Quick diagnostics
- Report upload
- Report analysis and remote diagnostics
- Read ECU version information
- Diagnostic system version management
- Software upgrade
- ECU software version management

Application Scenarios

- In-vehicle road testing
- Production line programming and fault diagnosis
- After-sales programming and fault diagnosis

Case 2

Commercial Vehicle Diagnostic System

Product Configuration: TPAD1003 + TC1113B

The Commercial Vehicle Diagnostic System is developed based on TSMaster and the Tongxing hardware tool TC1113B. It features modules for fault detection, actuation tests, connection status, and programming. The system helps after-sales and R&D engineers accurately identify and resolve vehicle issues, enhancing vehicle safety.



Case 3

Production Line Programming System

Product Configuration: TPAD2002

This system is developed based on the Tongxing TPAD2002 product and is designed to meet production line programming scenarios. The TPAD2002 integrates 2 CAN/CAN FD channels and 1 Ethernet channel, supporting programming via CAN/CAN FD and DoIP. The device features rugged industrial design, combining durability, compactness, and efficient protection.

Case 4

In-Vehicle Testing System

Product Configuration: TPAD2003

During full-vehicle and ECU development testing and verification, engineers often need to record bus data on the vehicle network for subsequent analysis. The in-vehicle testing system based on the Tongxing TPAD2003 can record and store various vehicle data, featuring automatic power-on startup, automatic bus recording, and automatic bus file upload.

When used with the Tongxing cloud platform, the system supports device configuration and management, test project management, bus file storage and management, account login modules, and account permissions and management. Bus file storage and management functions include DBC file upload and download, BLF file encryption and decryption, BLF file upload and download, advanced file search, bus data API interfaces, programming/calibration file upload, and custom file upload.

Configuration	CAN/CAN FD	FlexRay	Ethernet	Resources
2.0 Platform	6	1	X	TC1014+TC1034
3.0 Platform	4	1	1	TC1014+TEI051

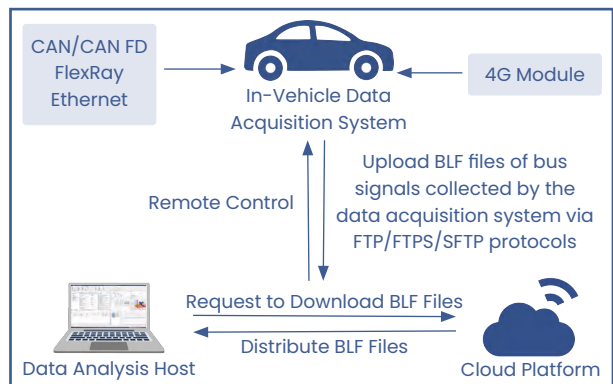
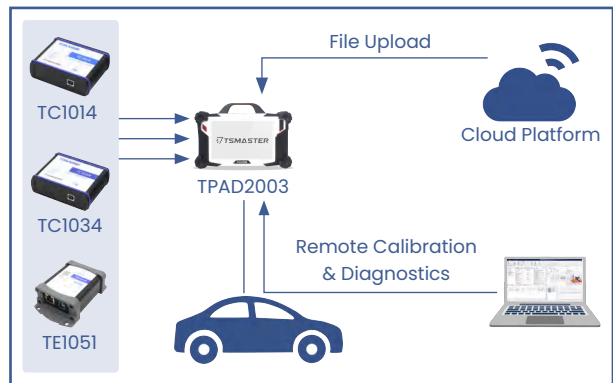

Case 5

In-Vehicle Test and Analysis Device Product Configuration: TPAD3005

The TPAD3005 is a tablet computer independently developed by Tongxing to meet the requirements of in-vehicle debugging tests. It supports 4 channel CAN data acquisition/playback, A2L variable loading, UDS diagnostics, XCP calibration, remote alarms, remote control, and feedback of alarm message information.

In addition to bus function modules, the TPAD3005 also integrates an oscilloscope system with protocol analysis capabilities. It can not only capture and display basic waveforms but also support the analysis of customer communication protocols. Moreover, it allows waveform acquisition using dedicated protocol data units as trigger conditions.

TPAD System Management Software:

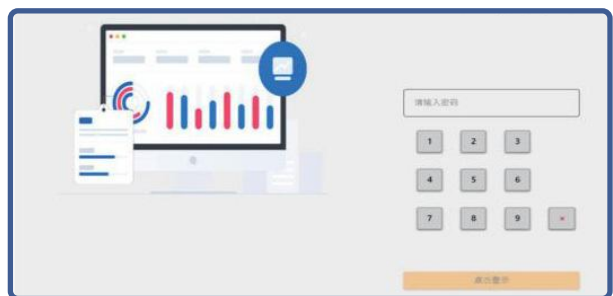

TPAD Series Ordering Information

NO.	Product	Model	Specification
1	Tablet PC	TPAD1003	Rugged industrial tablet (three-proof design)
2	Tablet PC	TPAD2002-C	2 channel CAN FD
3	Tablet PC	TPAD2003-1634	6 channel CAN FD, 2 channel LIN, 2 channel FlexRay
4	Tablet PC	TPAD2003-1651	4 channel CAN FD, 2 channel LIN, 2 channel Automotive Ethernet
5	Tablet PC	TPAD2003-3451	2 channel CAN FD, 2 channel FlexRay, 2 channel Automotive Ethernet
6	Tablet PC	TPAD2005-12	1 channel CAN FD, 1 channel LIN
7	Tablet PC	TPAD2005-13	2 channel CAN FD
8	Tablet PC	TPAD2005-14	4 channel CAN FD
9	Tablet PC	TPAD2005-16	4 channel CAN FD, 2 channel LIN
10	Tablet PC	TPAD2005-26	1 channel CAN FD, 6 channel LIN
11	Tablet PC	TPAD2005-34	2 channel CAN FD, 2 channel FlexRay
12	Tablet PC	TPAD2005-51	1 channel Automotive Ethernet
13	Tablet PC	TPAD3007-1634	6 channel CAN FD, 2 channel LIN, 2 channel FlexRay, enhanced winter version
14	Tablet PC	TPAD3007-1651	4 channel CAN FD, 2 channel LIN, 2 channel Automotive Ethernet, enhanced winter version
15	Tablet PC	TPAD3007-3451	2 channel CAN FD, 2 channel FlexRay, 2 channel Automotive Ethernet, enhanced winter version
16	Tablet PC	TPADScope	4 channel CAN FD, 4 channel analog input, bandwidth up to 200 MHz

Note: Other bus resources can be configured according to requirements



OTA HIL Test System

Functions

- Automated execution of full-link OTA testing
- Automated execution of GB 44496 compliance test projects
- Automated execution of HMI testing during OTA upgrade

Scenarios

- OTA Master self-upgrade testing
- Automated full-vehicle ECU OTA testing
- Automated multi-ECU, multi-task testing

Features

- Interacts with OTA Service to automatically set vehicle models and target ECUs, and automatically create upgrade tasks
- Supports simulation of strong, weak, and no-network environments
- Complies with R155, ISO 24089, and GB 44496 standards and regulations
- Supports HMI testing during the OTA upgrade process

Test Items

New Energy Vehicle OTA Automated Test Projects.

Regulatory Compliance Testing:

- Verify compliance with ISO 24089 software update standards and GB 44496 vehicle upgrade regulations, including mandatory checks such as pre-upgrade vehicle state validation

- OTA Functional Testing: Validate end-to-end OTA basic functions, including package download integrity, sequential multi-ECU flashing, real-time installation progress reporting, and user interruption recovery. Covers both normal OTA upgrade scenarios and abnormal upgrade situations
- OTA Performance Testing: Evaluate resource usage and timeliness during upgrades, monitoring central gateway peak load, CAN FD bus utilization, single ECU flashing time, and storage write speed in multi-ECU upgrade cases
- OTA Security Testing: Conduct penetration and anti-tampering tests in line with ISO 21434 and GB 44495, including man-in-the-middle attacks, replay attacks, and package tampering scenarios
- OTA Reliability Testing: Simulate extreme real-world conditions such as repeated power interruptions and recovery, continuous multi-ECU flashing, high/low voltage ECU interactions, inter-ECU flashing, power fluctuation tests, and weak/no-network conditions
- OTA Fault Testing: Build a multidimensional test matrix covering scenarios such as network disconnection during download, power loss during flashing, and brake failure during flashing
- User Experience Testing: Quantitatively evaluate interaction design, including clarity of upgrade prompts, accuracy of progress estimation, multimodal interaction (voice + display + mobile app synchronization), and feedback optimization

In-Vehicle Data Acquisition Solution

With the continuous advancement of automotive intelligence, software iteration cycles are becoming shorter, and the diversification of in-vehicle functions has made functional verification increasingly critical throughout the R&D process. During vehicle testing or ECU product validation, it is especially necessary to collect and analyze vehicle bus data (including CAN FD, LIN, Ethernet, etc.) as well as multi-source perception data from both inside and outside the vehicle in real-world road testing scenarios.

The TSMaster-based in-vehicle data acquisition solution enables efficient collection, accurate recording, and cloud storage of various bus data and video information. This allows R&D engineers to access and analyze road test data in real time from laboratory environments, greatly improving testing and validation efficiency while providing strong support for product development and optimization.

Functions

- Multi-bus data acquisition: Supports various mainstream automotive bus protocols (e.g., CAN FD, LIN, Ethernet)
- Audio & video data acquisition: Supports high-definition recording of in-vehicle and external environments with multi-channel audio/video synchronization
- Local storage of acquired data: Supports multiple formats, stable under large data volumes, efficient and reliable local storage
- Cloud upload of acquired data: Ensures secure and reliable transmission with encryption, supports data backup and access control

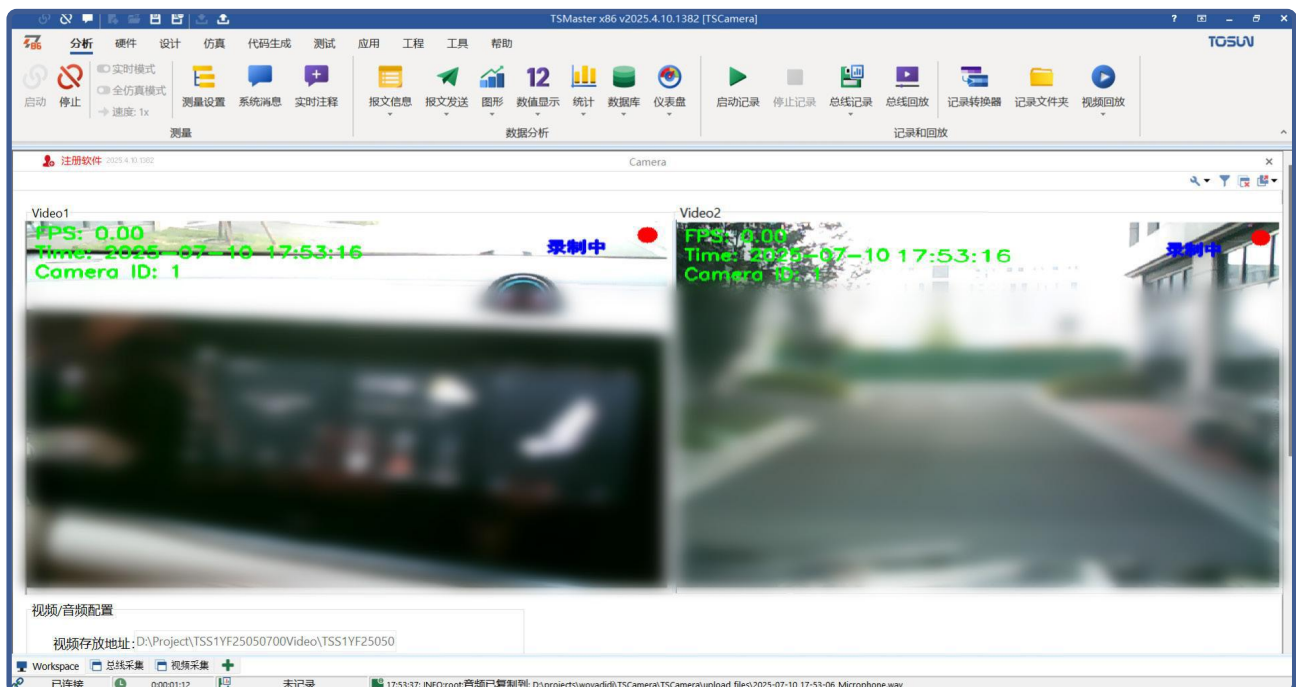

Cloud Platform Solution

In recent years, the rapid development of automotive technology, the shortening of iteration cycles, and the continuous expansion of vehicle functions have significantly increased the workload of calibration and validation. At the same time, with compressed product and innovation cycles, enterprises are facing severe challenges in terms of time, cost, and quality.

To address these challenges, enabling remote access to vehicle devices for remote testing can effectively reduce troubleshooting time, simplify problem tracking and handling processes, thereby improving efficiency and shortening development cycles.

TOSUN Cloud Platform is an integrated management solution that combines R&D testing and real-vehicle road testing. Designed with a modular architecture.

It mainly includes the following functional modules:

- Test equipment management
- Test data management
- Remote diagnostics
- Remote calibration

Application Scenarios

- Remote test bench data analysis
- Efficient and accurate road test data acquisition
- Remote vehicle flashing and fault diagnostic services

In addition, the TOSUN Cloud Platform supports private deployment and domain account integration, providing enterprises with a flexible and efficient solution for intelligent vehicle management, enabling a qualitative leap in testing and data management capabilities.

用例名	用例类型	文件存储地址	上传日期	上传者	操作
测试步骤B	文档	http://192.168.50.100:302...	2025-05-29 15:26:57	超级管理员	下载 删除
测试步骤1	程序	http://192.168.50.100:302...	2025-05-29 15:26:41	超级管理员	下载 删除

Accessories



2 pin phoenix connector

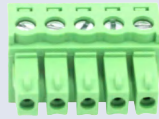

5 pin phoenix connector



20 pin FPC press fit connector

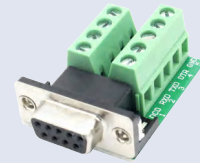

DB9 female connector



DB37 to 8 DB9 adapter cable



DB37 to 12 DB9 adapter cable



DB9 female connector to 2 banana



DB9 female connector to 3 banana(TC1016P)



DB9 female connector to 4 banana



DB9 female connector to 5 banana

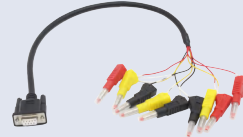

DB9 female connector to 9 banana



BAN to BAN connection cable



DB9 female to dual DB9 male signal cable (FlexRay)



DB9 female to dual DB9 male signal cable (CAN/LIN)



DB9 female to dual DB9 male signal cable (CAN)



MATenet Ethernet Cable



DB9 female with screwcigarette lighter cable



RJ45 Ethernet cable



DB9 to OBD adapter cable



KH-DB9CAN cable (MPI013)



Rosenberger H-MTD Cable



GPS Antenna



12V 2A power adapter



Surge Protection Device



+86 21-5956 0506



sales@tosunai.com



www.tosunai.com/en



Building 9, Lane 1288,
North Jiasong Road, Shanghai

Guangzhou - 3rd Floor, Block A, Lingnan Tech Center,
672 Daguan Middle Rd, Tianhe, Guangzhou

Beijing - Room 336, 3rd Floor, Block A, Xinhua Int'l Zhongye, 616
Gaolizhuang, Huaxiang, Fengtai, Beijing

Chengdu - Maikong Int'l Center, 3 Shunjiang Section,
Wuhou Ave, Wuhou, Chengdu

Taipei - 13th Floor, No. 908, Jingguo Road, Luzhu District, Taoyuan City

Germany - Hangweg 31 72669 Unterensingen, Stuttgart

Korea- 165, Convensia-daero, Yeonsu-gu, Incheon,
Republic of Korea F26 Room 2658



Youtube



LinkedIn



Website KR



Website DE



WhatsApp



Website US